

# GREATER LONDON AUTHORITY

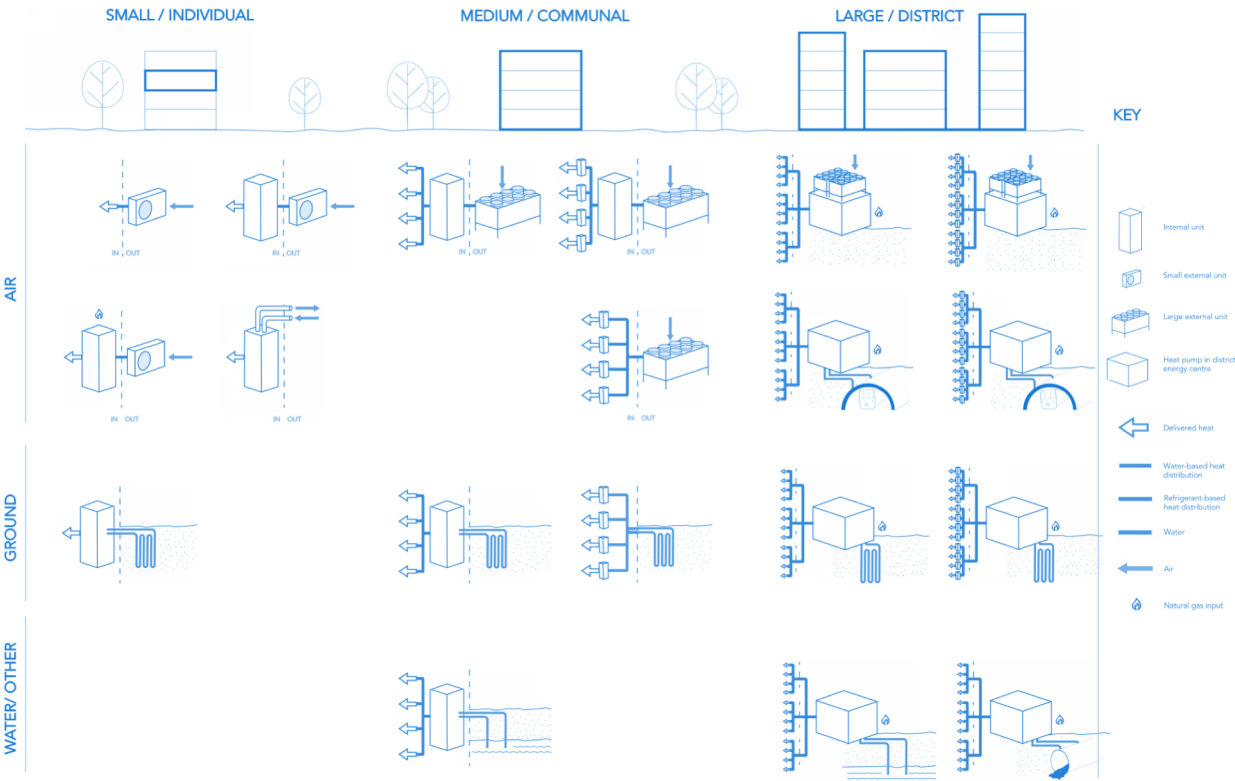

# LOW CARBON HEAT: HEAT PUMPS IN LONDON



## CONTENTS

<b>Acknowledgments</b> .....	<b>3</b>
<b>1.0 10-Minute Summary</b> .....	<b>4</b>
1.1 The importance of low carbon heat.....	4
1.2 Heat pumps in London: conclusions and recommendations.....	5
1.3 Types of heat pumps and important considerations.....	6
1.4 Heat Pumps – Market review.....	8
1.5 Impact of heat pump deployment.....	10
1.6 Review of key considerations and risks.....	15
1.7 Recommendations for the Greater London Authority.....	16
<b>2.0 This Study</b> .....	<b>17</b>
2.1 What is this study aiming to do?.....	17
2.2 What is not in the scope of this study.....	17
<b>3.0 The importance of low carbon heat</b> .....	<b>18</b>
3.1 Climate change and the need for action.....	18
3.2 Context: electricity decarbonisation.....	20
3.3 Carbon emissions and low carbon heat in London.....	21
3.4 Thinking about the consumer.....	25
<b>4.0 Setting the scene</b> .....	<b>26</b>
4.1 Heat pump: basic principle.....	26
4.2 Heat pump types.....	27
4.3 Efficiency of heat pumps.....	28
4.4 Approach to hot water.....	31
4.5 The importance of flow and return temperatures.....	32
4.6 Towards low carbon heat – Determining the carbon content of heat.....	32
4.7 Air quality is also a key driver.....	34
4.8 Literature review.....	34
4.9 Heating our buildings: a historical perspective.....	35
<b>5.0 Heat Pumps – Market review</b> .....	<b>37</b>
5.1 Heat pumps in other European countries.....	37
5.2 The heat pump market in the UK.....	39
5.3 Engagement with the supply chain and the building industry.....	41
5.4 Case studies.....	45
<b>6.0 Impact of heat pump deployment</b> .....	<b>51</b>
6.1 Energy and carbon.....	51
6.2 Impact on the electricity grid.....	60
6.3 Impact on capital costs.....	63
6.4 Impact on running costs.....	68
6.5 Impact on space.....	74
<b>7.0 Review of key considerations and risks</b> .....	<b>76</b>
7.1 Refrigerants.....	77
7.2 Noise impact.....	79
7.3 Design integration.....	81
7.4 Key risks and considerations.....	83

---

## APPENDICES

<b>Appendix A</b> - Historical and projected carbon factors for grid electricity .....	87
<b>Appendix B</b> - The different types of heat pumps .....	89
<b>Appendix C</b> - Heat pump efficiency background .....	92
<b>Appendix D</b> - Measures of heat pump efficiency .....	94
<b>Appendix E</b> - Data sources used to determine efficiencies .....	96
<b>Appendix F</b> - Main methods to generate hot water in buildings .....	97
<b>Appendix G</b> - The uncertainties associated with using 302 gCO <sub>2</sub> /kWh for the electricity carbon factor.....	99
<b>Appendix H</b> - Literature review .....	100
<b>Appendix I</b> - Who responded to the surveys? .....	102
<b>Appendix J</b> - High level capital cost study for a typical medium density apartment block .....	104
<b>Appendix K</b> - High-level review of heating costs for residents.....	106



# 1.0

10 - MINUTE SUMMARY

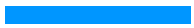

## 1.0 10-MINUTE SUMMARY

In the same way that a pump is used to move a fluid up hill, a heat pump is used to increase the temperature of a low temperature heat source (e.g. air or ground) to that of a high temperature heat sink (e.g. hot water for radiators) using electricity. In contrast to other heating systems, they do not require the local combustion of fossil fuels to generate heat. The heat source is generally free and can be renewable. A well designed, installed and operated heat pump can be very energy efficient. Over time, as grid electricity is increasingly sourced from renewables, the electricity used by heat pumps will also become lower carbon.

Etude have been commissioned by the Greater London Authority (GLA) to undertake a study into the implications of a more widespread uptake of heat pump technologies in London’s new developments, driven by the decarbonisation of the electricity grid. The project was funded by the GLA to support the development of an evidence base to inform the implementation of London Plan policies and the final London Environment Strategy publication.

This study focuses on heat pumps in new buildings. Existing buildings and other low carbon technologies are not in the scope of this study. This should not be interpreted as an endorsement by the GLA of heat pumps as the only alternative low carbon solution for new build or of a lesser importance of existing buildings. The study considers building level heat pumps as well as heat pumps used in low carbon heat networks to reflect the variety of solutions available. It establishes the key considerations and implications of a greater number of heat pumps in new buildings in London as they are likely to play a significant role in the delivery of low carbon heat.

### 1.1 The importance of low carbon heat

In order to achieve London’s carbon budgets as set out in the Mayor’s Environment Strategy, energy efficiency, low carbon electricity and low carbon heat are all essential. There is a consensus that the energy demand of buildings should reduce and electricity is decarbonising at a rapid rate (see figure below). This means that low carbon heat should be a priority going forward, which is also impacted by the grid decarbonisation as some forms of low carbon heat (e.g. heat pumps) use electricity.

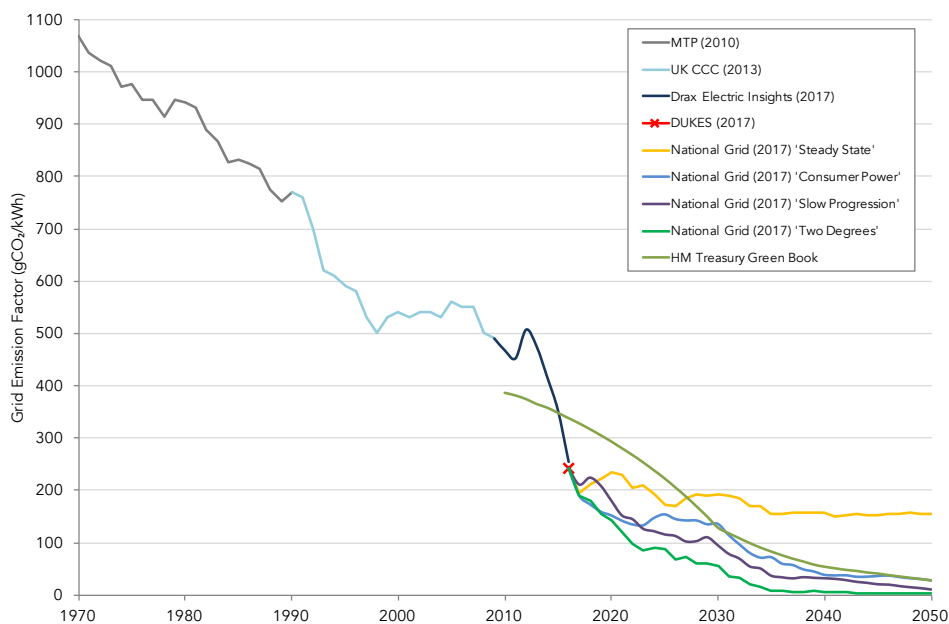

Figure 1.01 – Historic and projected carbon content of electricity

At a national level, the Committee on Climate Change has indicated that the current deployment of heat pumps and low carbon heat networks is below the level required to meet future carbon budgets. It suggests that by 2030, 2.5 million heat pumps should be installed in new homes and that low carbon heat networks should deliver around 40 TWh across the UK. By 2050, heat should be delivered in non-hydrocarbon forms and it recommends that gas boiler installations should cease by 2035.

The Mayor has set a target for London to become a zero carbon city by 2050. The London Environment Strategy stresses that, over the next two decades, dependence on natural gas must be reduced by increasing the use of low carbon heat (including harnessing energy from water, ground and air using heat pumps) as well as capturing more of the heat wasted from buildings and infrastructure and using heat networks in the densest areas of the city to distribute it to London's homes and workplaces. It also identifies air quality as a pressing environmental threat to the future of health in London. The Mayor of London is now seeking to design integrated policies which deliver co-benefits between air quality and climate change policies.

Protecting Londoners against unintended consequences is also crucial. Approaches to heating can and do change but new systems always introduce challenges. Specific concerns regarding heat pumps should be acknowledged and addressed. These include very high energy costs when the 'wrong' type/size of heat pump has been installed, a higher level of complexity of some systems or potential difficulties and costs associated with maintenance.

## 1.2 Heat pumps in London: conclusions and recommendations

One of the key messages of this report is that there is a wide variety of heat pump system architectures that could provide heat for new developments in London and that it is difficult to draw conclusions applicable to all types and all scales. Our proposed 10 key conclusions are the following.

1. Heat pumps are very likely to play a growing role for the delivery of low carbon heat in London, both as part of low carbon heat networks (e.g. using waste heat as a source) and as building-only heating systems. New buildings offer an opportunity to generate faster changes in the market for this type of low carbon heat solution.
2. When applying a more up-to-date carbon factor for electricity (e.g. 233 gCO<sub>2</sub>/kWh proposed in SAP 10) heat pumps are a substantially lower carbon system than gas-based solutions (e.g. gas boilers and/or gas-fired Combined Heat and Power) or direct electric options; and the electricity carbon factor is also expected to decrease further in the future.
3. In order to deliver low carbon and affordable heat, the efficiency of heat pumps needs to be better understood by the building industry. The use of low temperature distribution systems and emitters, the method used to generate domestic hot water and the correct installation and commissioning of heat pump systems can all help to deliver low carbon emissions and operational energy costs. Heat pumps should not be seen as direct like-for-like replacements for gas-fired CHP.
4. Maintenance costs can form a substantial part of overall end-user heating costs in new developments and should be included in any evaluation of running costs of heat pumps. Efficient heat pumps offer a cost competitive form of heating.
5. It is very difficult to draw a simple conclusion on capital costs given the variety of systems and the range of costs within a single system type. However, on average, the capital costs of heat pumps are likely to be slightly higher than a 'business as usual' heating system with central gas boilers and a gas-fired CHP. A number of developments with heat pumps exist, which demonstrates that they are already viable in a commercial setting.

6. Potential additional capital costs compared with 'business as usual' are likely to be small in comparison to the total project costs though (0-3%) and should be seen in conjunction with their potential benefits including carbon and air quality. Research commissioned by the Government in 2016 also suggests that costs could reduce by 15-20% in future.
7. The impact of heat pumps on space and noise is very dependent on the system type and it requires consideration on a project-by-project basis.
8. The majority of refrigerants currently used in heat pumps have a high global warming potential and can present other risks. Regulatory frameworks are in place to address these concerns though and the industry appears to be working to mitigate these risks.
9. The key considerations for a wider uptake of heat pumps include mechanical design (particularly supply temperatures and Domestic Hot Water (DHW) provision), architectural integration, installation quality, commissioning and maintenance. More work is required to ensure that they will not have unintended consequences, but none of these considerations are thought to be significant barriers. Heat pumps can also have the advantage of being 'smart grid' ready (therefore a demand side management opportunity).
10. Heat pump suppliers would be able to sustain an uptake in demand as they supply other European countries with much higher volumes of heat pumps installed annually. The industry as a whole needs to be capable of dealing with an increased demand.

### 1.3 Types of heat pumps and important considerations

There is a significant variety and diversity of heat pump systems (both in terms of scale and types) and it often confuses the debate as some advantages or concerns only apply to some of them. In order to enable a clear appraisal, Section 4.0 proposes a simple taxonomy based on type and scale.

#### Ensuring heat pumps operate efficiently

This study proposes that there is a need for clarification on the metrics to be used to establish the efficiency of a heat pump system (and therefore its impact in terms of running costs and carbon savings). It uses the Seasonal Coefficients of Performance (SCOP) as the key metric which is then referred to as 'efficiency' for clarity. Please refer to the Appendix for more details.

The efficiency of a heat pump, unlike a gas boiler, can vary substantially. The two most important factors that affect heat pump efficiency are the **heat source temperature** and the **heat distribution system temperature**. The closer these temperatures are to one another, the higher the efficiency of the heat pump. Importantly, these temperatures are often influenced by heat emitter type selection, design and sizing. The heat pump system design should influence the emitter design to achieve optimum efficiency.

The importance of minimising this temperature difference and how best to achieve it in practice must therefore be clearly understood by designers, installers and end-users if heat pumps are to operate efficiently. A range of data sources were used to determine a realistic range of efficiencies for use in this study. The data sources and ranges of performance included several field trials in the UK and Europe, values used by public authorities and manufacturers' test data. They indicate that heat pumps can operate at high efficiency if designed, installed and commissioned well.



**Approach to hot water generation and the importance of flow and return temperatures**

The efficiency of a heat pump system reduces as the temperature it is required to supply increases. Unlike the provision of space heating which can be supplied at lower temperatures, the generation of domestic hot water (DHW), which generally requires a temperature of 60°C or above due to health and safety considerations, can reduce a heat pump system’s efficiency. A range of DHW system architectures exist (e.g. separate provision of space heating and hot water, single provision at a high temperature) and it is an important consideration. More generally, heat pumps cannot be considered in isolation from the heat distribution system they will supply. The mechanical design of building services must therefore evolve to ensure heat pumps operate efficiently.

**Towards low carbon heat – Determining the carbon content of heat**

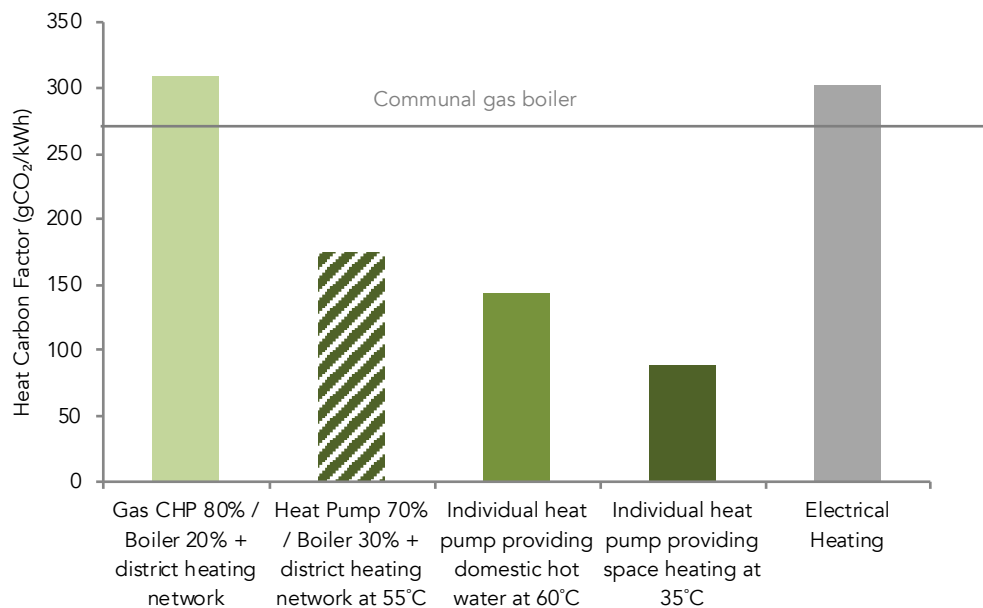

**Figure 1.02 – Carbon factor of heat based on 302 gCO<sub>2</sub>/kWh\***  
 For details behind this assessment (e.g. distribution losses), please refer to Section 4.0.

Despite this, and as shown on Figure 1.02, heat pumps can provide heat (for district heating, domestic hot water and space heating) at lower carbon factors than gas-fired CHP led systems and direct electrical heating.

The analysis uses a carbon factor for electricity of 302gCO<sub>2</sub>/kWh to be consistent with other energy evidence bases prepared for the GLA by Buro Happold and AECOM. It is higher, and therefore less favourable to heat pumps, than the carbon factor proposed for SAP 10 (i.e. 233gCO<sub>2</sub>/kWh). Savings from heat pumps would be even greater with a lower carbon factor.

## 1.4 Heat Pumps – Market review

### Heat pumps in other European countries

According to the European Heat Pump Association (EHPA) 2017 market report, there were approximately 1 million heat pump units sold in the EU in 2016 and the market was dominated by small-scale systems (<20kW) which account for 90% of the sales. There are three countries where more than 100,000 units were sold in 2016: France (>220,000 units), Italy (>180,000 units) and Sweden (>100,000 units). This is significantly more than the 20,000 units sold in the UK.

Generally Nordic countries have the highest market penetration rate of heat pumps. In particular, Norway has the highest share of heat pumps proportion with more than one third of all household equipped with a heat pump. 95% of new heating systems are heat pumps. The UK is at the other end of the scale with heat pumps representing less than 1% of new heating systems.

### The heat pump market in the UK

According to the Building Services Research and Information Association (BSRIA) 2018 market report, the total number of heat pump units sold per year in the UK is relatively stable at approximately 20,000-22,000 units per year (excluding air-to-air units). 83% of all homes in the UK are heated by gas with individual gas boilers the most common solution by far and the majority of other homes are heated by electric storage heaters, oil and LPG. The number of homes served by heat pumps in the UK is therefore very limited. They do, however, represent a growing proportion of the new build market.

Approximately 48% of all heat pumps are sold in the 'existing/retrofit' market and 52% of them (i.e. approximately 11,500 heat pumps per year) are sold in the new build sector. The vast majority of heat pumps sold are for individual dwellings.

### Engagement with the supply chain and the building industry

Seven surveys were prepared and sent to various stakeholders, from heat pump suppliers and installers to developers, housing associations, London Boroughs energy officers and engineers. 81 people responded to the study. The focus was on new build but not restricted to London.

When asked about the main **challenges** to a rapid increase in the uptake of heat pumps, the five key themes repeated across several responses were:

- The need for mechanical design of building services to evolve, particularly to enable lower supply temperatures;
- The higher capital costs of heat pumps relative to gas boilers;
- The additional training and skills required to deliver quality installations;
- The greater level of expertise required during commissioning compared a typical gas boiler installation (e.g. to avoid electric back-up immersion heater being set as default);
- Maintenance (e.g. smaller number of companies able to maintain heat pumps compared with gas boilers).

**Which proportion of projects include heat pumps?**

According to the survey responses summarised in the adjacent pie chart, the proportion of new build projects with heat pumps is not insignificant and suggests that they are an increasingly common solution.

It should also be noted that the majority of developers, housing associations and local authorities also expect the proportion of heat pumps to increase in the future.

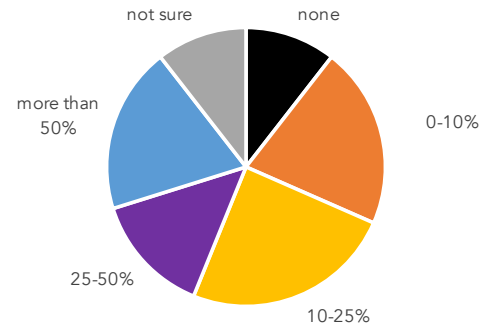

**Key benefits of heat pumps**

Although the opinions diverge on what the most important benefits of heat pumps are, on average the following ranking can be established from the respondents:

1. Lower carbon emissions
2. No combustion/local pollution
3. No gas connection
4. Lower running costs
5. Safety

**Do you expect heat pumps to become the main solution for heating in the future?**

More than two thirds of the respondents (excluding heat pump suppliers and installers) seem to believe that heat pumps will become the main heating solution in the future, with some of them thinking that it will only happen in the longer term.

Less than 10% of the respondents think that heat pumps will not become the main solution for heating while 28% are unsure.

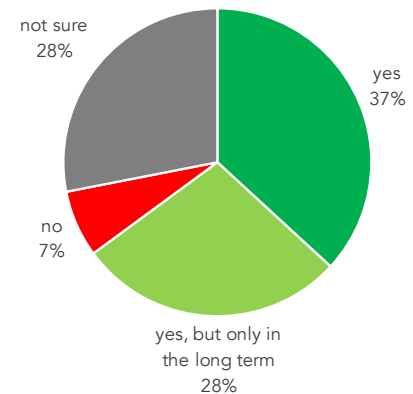

**Key reasons why heat pumps are not specified more**

Again, the opinions diverge on what the key perceived issues are with heat pumps but, on average, the following ranking can be established from the respondents:

1. Lack of user/client awareness
2. Capital costs
3. Mechanical design / technical feasibility
4. Architectural integration / visual impact
5. Electricity grid limitations
6. Concerns over maintenance
7. Running costs
8. Noise

### 1.5 Impact of heat pump deployment

This section of the report provides an initial review of the implications heat pumps would have in terms of carbon savings, capital costs, running costs, space and noise when compared to a 'baseline' approach relying on a connection to a District Heating network with gas-fired boilers and CHP.

#### Part L compliance, energy and carbon

Several case studies of common development types in London were investigated and have been modelled with the described heat pump systems. While many other system architectures are possible, it was considered that these combinations would provide a reasonable indication of the impact of heat pumps on energy and carbon savings against a 'business as usual' scenario based on gas-fired CHP. For details on our assumptions, please refer to Section 6.0.

The following bar chart indicates the modelled heat pump system performance against Part L using a grid electricity carbon emissions factor of 302 gCO<sub>2</sub>/kWh for all calculations in place of the outdated figure that is currently used (i.e. 519 gCO<sub>2</sub>/kWh). The heat pump systems perform better against Part L than the alternatives across all building types considered. This is due to a combination of the efficiency heat pumps can achieve, decarbonisation of grid electricity and reduction of distribution losses.

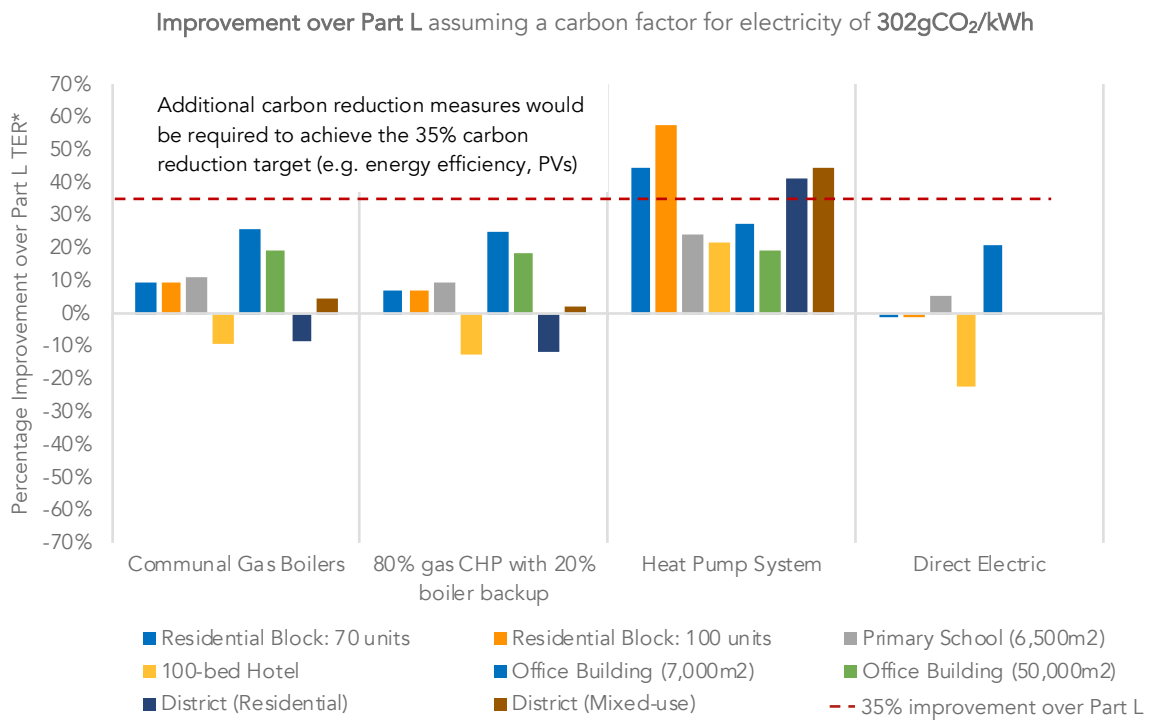
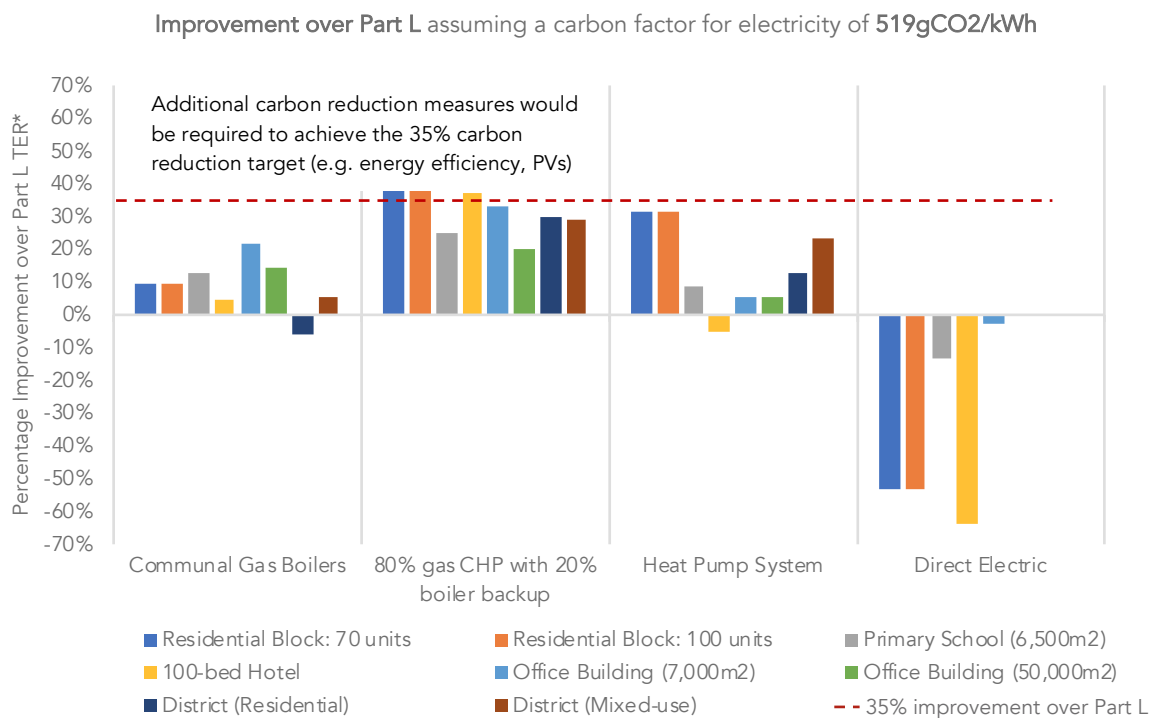

Figure 1.03 - Comparison of Part L improvement results (assuming a carbon factor of 302gCO<sub>2</sub> /kWh for electricity)

As it is recognised that Part L is primarily a Building Regulations compliance tool and is not meant to predict actual energy consumption, a second energy assessment based on benchmark energy data has also been undertaken. In each case the heat pump system scenario achieves greater carbon savings compared to the communal gas boiler scenario. CHP and direct electric were found to be consistently worse than gas boilers across the board (assuming a carbon factor for electricity of 302 gCO<sub>2</sub>/kWh). It needs to be highlighted that heat pumps are able to provide the greatest energy efficiency and carbon saving benefits **when the overall heating / hot water system is designed around their characteristics** (e.g. greater efficiency when supplying lower temperatures). For this reason, new buildings offer an opportunity to optimise heat pump efficiencies.

For comparison, the graph below indicates what the current Part L performance of these systems would be, using a carbon factor for electricity of 519gCO<sub>2</sub>/kWh as it is used in SAP 2012.



**Figure 1.04 - Comparison of Part L improvement results (assuming a carbon factor of 519gCO<sub>2</sub> /kWh for electricity)**

When compared, Fig 1.03 and Fig 1.04 indicate very clearly that the decarbonisation of the grid is affecting Part L performance. The reduction of the carbon factor for electricity from the out-of-date 519gCO<sub>2</sub>/kWh to 302gCO<sub>2</sub>/kWh particularly affects the comparison between heat pumps and gas-fired CHP.

The use of an even lower carbon factor for electricity (e.g. 233gCO<sub>2</sub>/kWh as proposed in SAP 10) exacerbates these findings (see Section 6.1 for further details).

Looking ahead to 2030, preliminary analysis indicates that very low levels of total on-site carbon emissions (i.e. approximately 2kgCO<sub>2</sub>/m<sup>2</sup>/yr) can be delivered if very high standards of energy efficiency are achieved, an efficient heat pump system is provided and roof-mounted PVs are maximised. Energy efficiency reduces demand to the lowest level, heat pumps deliver low carbon heat and PVs play a significant role in offsetting on-site the residual carbon emissions.

### Impact on the electricity grid

The impact of heat pumps on the electricity grid is often quoted as one of the barriers to a greater uptake of heat pumps in London. At the distribution system level, UK Power Networks conducted studies into the impacts of electric vehicles and heat pumps on their infrastructure. Potential impacts on the grid are of two types: on **capacity** and on **power quality**. The impact on capacity would be the result of a significant market penetration of heat pumps. The impact on power quality would be the result of clustering: a high number of heat pumps in a given location.

UK Power Networks (UKPN) has indicated that it does not currently see a significant market penetration of heat pumps in London. Given the slow turnover of building stock in London, this is not surprising. The increase in the number of EVs appears to be more significant to UKPN in the short-medium term. UKPN has indicated that it will actively plan for additional demand due to heat pumps, provided it has early visibility of any deployment plans, and are notified of installations on their networks.

The opinions of mechanical and electrical engineers (collected with the survey) on the impact of heat pumps on the electricity grid were interesting. A quarter (24%) of respondents indicated that the integration of heat pumps led to significant additional cost on their project. However, the majority of respondents (76%) did not highlight the cost impact as significant. A few respondents highlighted that the cost impact was dependent on the local network and its potential need for reinforcement. UKPN recommend that the cost of connecting to the networks is taken into account, alongside the cost of the technology itself.

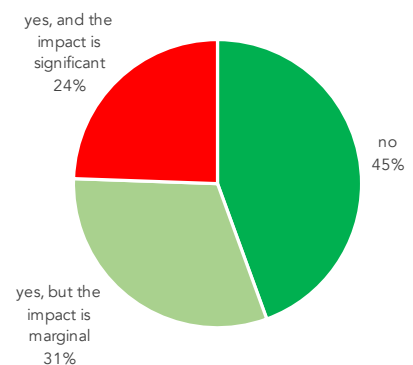

### Impact on capital costs

Assessing the impact of heat pumps on capital costs for developers is challenging: firstly due to the variety of new building types and scales in London, but most importantly due to the variety of heat pump systems which can be applied to each building type and to the wide range of costs of these systems.

The fact that heat pump systems are already used in office buildings for example can be used as evidence that their cost does not have a significant impact on viability for commercial buildings. On the other hand, the fact that they are not often installed on medium/large residential buildings suggests that their impact on additional costs for the developer should be considered.

An assessment of a selected number of systems on capital costs for the developer of a medium scale residential building has therefore been undertaken. It compares the Mechanical and Electrical capital costs of heat pump systems against a baseline relying on a connection to a District Heating system with gas-fired CHP. As an example, for a communal ground loop connected to individual heat pumps (Ground source Medium G-2), the ground loop would introduce significant additional '*infrastructure costs*' but also savings in terms of '*building costs*' as no central plant room would be required. However, it would also lead to additional '*dwelling costs*' due to the replacement of the heat interface unit with the individual water-to-water heat pump and its hot water cylinder.

The scale of additional costs is indicated qualitatively by 1 to 5 '+'. The scale of savings by 1 to 5 '-'. It indicates that costs comparisons are very dependent on the heat pump system. It shows that individual systems can add significant costs at the dwelling level.

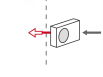
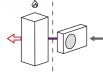
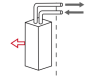
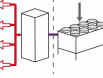
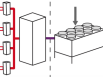
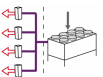
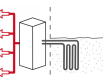
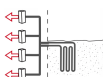
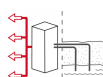
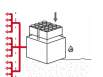
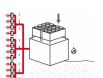
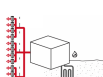
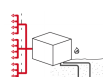
Type	Ref	Example	Capital cost implications for developer		
			Infrastructure	Building	Dwelling
AIR SOURCE Small-A1		Monobloc	--	---	++++
AIR SOURCE Small-A3		Hybrid	-	---	+++++
AIR SOURCE Small-A4		Compact unit Heat Pump + MVHR	--	---	+++++
AIR SOURCE Medium-A1		Communal air source heat pump to heat interface units (HIUs)	--	++	=
AIR SOURCE Medium-A2		Communal air source heat pump to heat pumps	--	+	+++
AIR SOURCE Medium-A3		Communal VRF system air source heat pump to individual heat pumps	--	+	++
GROUND SOURCE Medium-G1		Communal closed-loop ground source heat pump to heat interface units (HIUs)	++	+	=
GROUND SOURCE Medium-G2		Communal ground loop connected to individual heat pumps	++	-	++
WATER SOURCE Medium-W1		Communal water source heat pump to heat interface units (HIUs)	+	++	=
AIR SOURCE Large-A1		DH network with primary air source heat pumps	=	=	=
AIR SOURCE Large-A2		4 <sup>th</sup> generation DH network with air source heat pumps and heat pump in each building	=	+	=
GROUND SOURCE Large-G1/2		4 <sup>th</sup> generation DH network with ground source heat pumps and heat pump in each building	=	+	=
WATER SOURCE Large-W1/2		DH network with primary water source heat pumps	=	=	=

**Table 1.01 – Qualitative appraisal of additional costs and cost savings for the developer of a medium density apartment block**

*Please note that the above analysis includes only the most common system types*

The analysis undertaken as part of this study suggests that heat pump solutions are likely to cost between 0.4% and 2.9% of total build costs above traditional solutions for a medium density apartment building (excluding any potential electricity infrastructure costs) but this is very dependent on the system and the design. It should also be noted that DECC (now BEIS) published two reports in 2016<sup>1</sup> highlighting that heat pump costs could reduce by 15-20% in future.

**Impact on running cost**

The approach adopted for this high-level assessment was to consider heating costs from the perspective of the residents living in an energy efficient new build 2-bedroom apartment of 70 sqm requiring 4,200kWh of heat per year rather than the landlord or the energy system operator (this was chosen as it represents a good practice level of energy consumption in London). When looking only at the energy cost component (i.e. the direct costs related to metered energy) a simplistic comparison of predicted future heating bills can be misleading. The reason for this is that, depending on the scale of the system, some costs may or may not be embedded in the heating bills. For example, whereas the heating bill for an individual gas boiler only includes the cost of the gas consumed and the standing charge for the gas connection, the heating bill associated with a communal/district heating system generally includes other costs (e.g. maintenance, replacement, etc.). Energy costs, maintenance costs/charges, replacement costs, standing gas charge, metering/billing charge and other charges were therefore considered in the comparison illustrated in the bar chart below. The error bar indicates the level of uncertainty associated with each system.

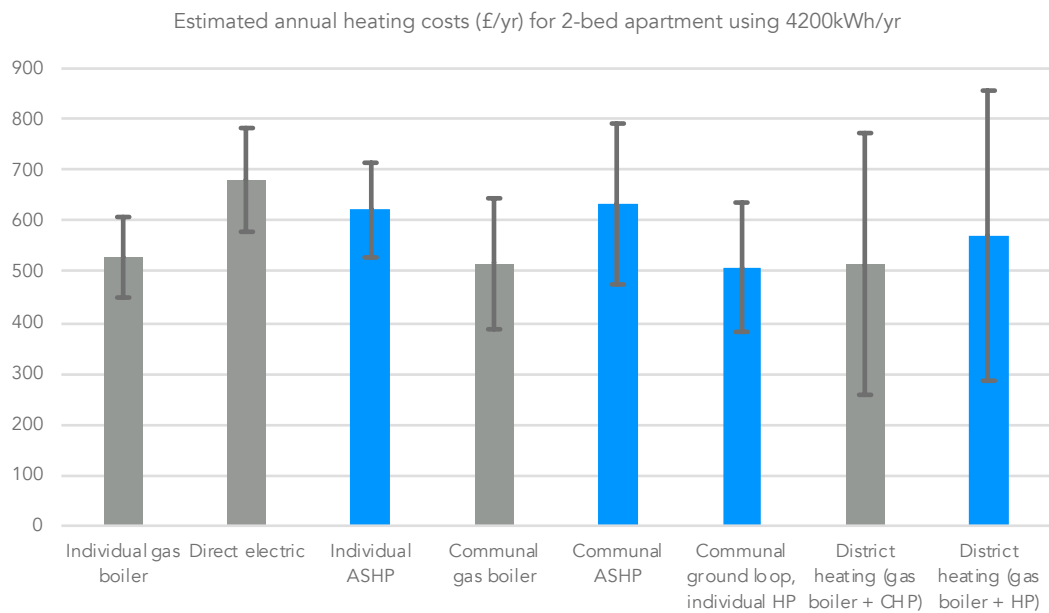

**Figure 1.05 - Comparison of predicted heating costs for the resident of a 2-bed energy efficient apartment**













The bar chart above indicates that typically heat pump solutions are likely to lead to an increase in annual heating costs (0-20%) compared with the cheapest non-heat pump solution (communal gas boiler). However, there are cheaper and very efficient systems (e.g. communal ground loop with individual heat pumps). Costs associated with a communal air source heat pump system ('Communal ASHP above') will be lower if electricity is purchased at a cheaper rate (which larger customers can negotiate). The costs of metering and billing are also an important component of all communal and district scale systems and should be reduced to a minimum to maintain low heating costs.

<sup>1</sup> Potential cost reduction for heat pumps: the scope for a mass market, Delta-EE for DECC, 2016



## 1.6 Review of key considerations and risks

We asked participants in the surveys to express whether they thought that the following factors were a **low**, **medium** or **high risk**.

-  Commissioning
-  Installation quality
-  Noise impact on neighbouring properties
-  Air quality (for hybrid systems)
-  Visual impact
-  Internal levels of noise
-  Ground water temperature over the long term
-  Urban heat island
-  Impact on internal layouts (e.g. apartments)
-  Decommissioning
-  Legionella risk
-  Fire safety
-  Refrigerant leak

The report includes an explanation on these risks focusing particularly on installation quality, commissioning, maintenance, refrigerants and design integration. Our analysis of these risks concluded that none of them are significant barriers and can be managed and mitigated through appropriate design. The negative impact of refrigerant leakage (e.g. HFCs) in particular, which is currently being addressed by UK regulation, was found to be minimal and can be mitigated.

## 1.7 Recommendations for the Greater London Authority

Our key recommendations for the GLA include:

- a. **Updated emission factors:** Enable a more accurate assessment of the carbon content of heat by adopting a carbon content of electricity which reflects reality in place of the outdated Part L carbon factor, when assessing new developments.
- b. **Heat pump efficiencies:** Provide guidelines to applicants on which default values they should use when assessing heat pump systems.
- c. **Ultra-low temperature heating systems:** Consider a policy or a guidance requirement for in favour of ultra-low temperature distribution and emitters in all new developments.
- d. **Quality and performance gap:** Prepare guidelines for applicants on good practice design, installation and commissioning of heat pumps that they should adhere to, in the absence of national guidance. The GLA may also want to have specific guidelines focusing on efficiency and residents/customers. The MCS and GSHPA standards could be used a basis for this.
- e. **Handover and consumer protection:** Require applicants to assess the likely future cost of heat for residents and provide them with information on controls and efficient operation.
- f. **Electricity grid:** Collaborate with UKPN to monitor the gradual impact of the electrification of heat on the capital's electrical infrastructure.
- g. **Architectural integration:** Develop good practice recommendations for architectural integration of heat pumps (e.g. internal space, layout and access, integration of external equipment).
- h. **Case studies:** Gather information on completed or under construction residential heat pump projects.

# 2.0

THIS STUDY



## 2.0 THIS STUDY

Etude has been commissioned by the Greater London Authority (GLA) to undertake a study into the implications of a more widespread uptake of heat pump technologies in London's new developments. As the electricity grid continues to decarbonise and buildings become more efficient, a move towards heat pump led solutions could potentially help to address both carbon and air quality challenges.

The project was funded by the GLA to support the development of evidence base to inform the implementation of London Plan policies.

### 2.1 What is this study aiming to do?

The specifications for the study highlighted three key tasks to be undertaken

- a heat pump market review;
- an assessment of the high level impact of heat pump deployment in new buildings (e.g. carbon reduction, capital costs, running costs, space requirements);
- a review of the potential risks of high heat pump deployment.

### 2.2 What is not in the scope of this study

Although the study touches on many aspects associated with heat pump design and operation, the aim of the study was not to propose an optimal design or recommend the installation of a particular heat pump type. It will show that there is a significant breadth of heat pump solutions with different scales, heat source, technologies and heat distribution systems and that it is important to select and design the right system for the context.

It is not a detailed investigation into the impact of heat pumps on the electricity grid in London.

The ability of heat pumps to provide cooling is one of their potential advantages. However, as this study focuses on low carbon heat and as they can be used both as heating only or as heating and cooling system, cooling is not covered in this study.

This study focuses on heat pumps in new buildings. Existing buildings and other low carbon technologies are not in the scope of this study. This should not be interpreted as an endorsement by the GLA of heat pumps as the only solution or of a lesser importance of existing buildings.

The aim of this study is not to conclude whether building level heat pump systems are a better solution than low carbon heat networks (which could also include heat pumps) as the conclusion will be very dependent on the context, but merely to determine whether heat pumps can play a significant role in low carbon energy systems in London.

# 3.0

## THE IMPORTANCE OF LOW CARBON HEAT

---

Mitigating climate change and delivering zero carbon new buildings in London require a combination of better energy efficiency, low carbon electricity and low carbon heat.

The carbon pathways developed by Committee on Climate Change and the Greater London Authority both rely on a significant uptake in heat pumps in the next 10-15 years to deliver low carbon heat.

The Mayor's Environment Strategy seeks to achieve co-benefits between carbon emissions and air quality. Heat pumps have a lower impact on air quality than most alternatives.

## 3.0 THE IMPORTANCE OF LOW CARBON HEAT

This section explains why low carbon heat is crucial to the delivery of London's climate change mitigation objectives. After a short explanation of the scientific and international consensus, it provides a summary of the national and local policy context.

### 3.1 Climate change and the need for action

#### 3.1.1 Scientific consensus

There is overwhelming scientific consensus that significant climate change is happening. This is evidenced in the latest assessment of the Intergovernmental Panel on Climate Change (IPCC AR5). Climate change is leading to rising temperatures and sea levels, causing extreme weather, damaging ecosystems, reducing the productivity of crops and changing the natural environment. Many impacts are already being detected globally. It is extremely likely that human activity is the predominant cause of climate change through emissions of greenhouse gases (GHG).

#### 3.1.2 The Paris Agreement (2015)

International negotiations on climate change are governed through the United Nations Framework Convention on Climate Change (UNFCCC). The most recent negotiations concluded with the Paris Agreement in December 2015. This Agreement reaffirms global ambition to limit temperature rises to below 2°C and binds every country to produce national plans to reduce emissions. The agreement also contains a further collective aspirational goal to reduce emissions in line with keeping the temperature increase to 1.5°C.

Analysis by the Department of Energy and Climate Change (now BEIS) suggests that the appropriate contribution from the UK to the global 2°C objective would be equivalent to a 58% to 62% reduction in emissions from 1990 levels by 2030.

#### 3.1.3 Key national policy

The Climate Change Act 2008 commits the government to reducing the UK's carbon emissions by at least 80% by 2050 compared with a 1990 baseline. This target was advised by the Committee on Climate Change (CCC) as an appropriate share of global action to limit global surface warming to around 2°C above pre-industrial levels by 2100. The Government has recently asked the CCC for advice on whether this target should be strengthened.

A series of energy policy documents relating to buildings and heat have been produced since the Climate Change Act 2008. These documents outline some of the policies required to reduce carbon emissions. These include: The UK Low Carbon Transition Plan (2009), The Carbon Plan (2011), The Future of Heating: A strategic framework for low carbon heat in the UK (2011), The Future of Heating: Meeting the challenge (2013) and The Clean Growth Strategy (2017).

A consistent theme in these documents is the need to increase energy efficiency and decarbonise the heating of buildings for the 2050 target to be achieved.

### 3.1.4 The Committee on Climate Change recommendations

The most recent report from the Committee on Climate Change<sup>2</sup> shows that UK emissions fell 6% in 2016<sup>3</sup> and are down 19% since 2012 but that progress has been dominated by the power sector (reduction in the use of coal for power generation, which is now at low levels, and increased contribution from renewable energy).

Direct carbon dioxide emissions from buildings actually rose in 2015 and 2016<sup>4</sup>. The report notes that:

- the rates of installing insulation have stalled (down over 90% from 2012);
- new buildings with **high-carbon heating systems are still being built**;
- the **deployment of heat pumps and low-carbon heat networks is below what is required** for meeting future carbon budgets.

The Committee on Climate Change suggests measures to deliver carbon reductions in the building sector. These include:

- Energy efficiency improvements to existing buildings, including insulation of all practicable lofts by 2022 and cavity walls by 2030, and 2 million solid walls by 2030;
- Stronger new build standards for energy efficiency and low-carbon heat;
- **Low carbon heat, including 2.5 million heat pumps in homes by 2030**, around 40 TWh of low-carbon heat networks by 2030 and around 20 TWh of biomethane to the gas grid by 2030.

The report also notes that there is no robust evidence to suggest that the introduction of new energy efficiency/low carbon heat standards for new homes would appreciably reduce or delay new housing supply to meet Government targets for new housing.

The CCC report *Next steps for UK heat policy* in 2016 examined pathways to decarbonise heat used within buildings by 2050<sup>5</sup>. The report clearly states that **by 2050, heat will have to be delivered in non-hydrocarbon forms**. It recommends that gas boiler installations should end by 2035 to avoid the need for scrappage schemes. It highlights three main alternatives:

1. Electricity (e.g. **heat pumps**);
2. Low carbon district heating for dense areas (*which could include heat pumps*);
3. Hydrogen via a modified gas network.

Finally, the report recommends principles that should guide policy development including the **focus on real world performance**, the development of a **joined-up approach between building fabric efficiency and low carbon heat**, and the need for industry to be aware of the solutions and capable of delivering them.

---

<sup>2</sup> Meeting carbon budgets – 2017 progress report to Parliament: Closing the policy gap, CCC

<sup>3</sup> Total UK emissions of GHG in 2016 were estimated to represent 466 million tonnes of CO<sub>2e</sub> (466 MtCO<sub>2e</sub>)

<sup>4</sup> Direct building GHG emissions represented 89 MtCO<sub>2e</sub> in 2016. Indirect building GHG emissions (i.e. electricity used in buildings) represented 52 MtCO<sub>2e</sub> in 2016. Total GHG emissions for buildings were therefore 141 MtCO<sub>2e</sub>.

<sup>5</sup>This requirement was first outlined as a priority in the 2011 Low Carbon Transition Plan

### 3.2 Context: electricity decarbonisation

Establishing the likely future grid carbon factor over the period 2019-2034 and beyond can help to inform the development of London’s low carbon heat strategy. It will not only affect building CO<sub>2</sub> emissions due to electricity use for lighting, equipment, etc but also the carbon content of heat produced from heat pumps, electrical heating and technologies that offset emissions against the grid, such as gas-fired Combined Heat and Power (CHP).

Each year, the National Grid produces a set of UK future energy scenarios. The most recent version covers the period from 2017 to 2050 and considers both energy supply and demand. Four different scenarios are used to develop predictions using a range of technical, financial and societal variables.

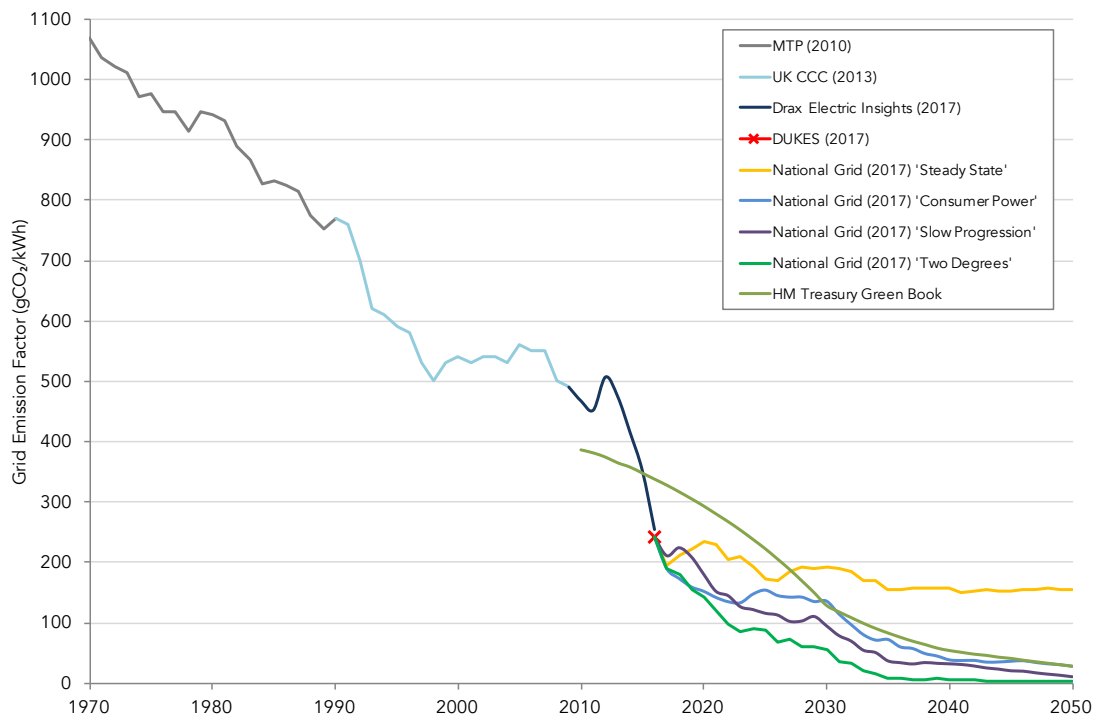

Figure 3.01 – Historic and projected carbon content of electricity

As well as the Treasury forecast, Figure 3.01 shows different projections for the future decarbonisation of electricity.

The 'slow progression' scenario can be considered as a plausible balance of progress toward the goals of the Climate Change Act 2008 while applying economic constraints to progress. Low economic growth is assumed, with affordability of energy remaining a key policy driver that competes with the need to reduce carbon emissions throughout the assessment period. This scenario ultimately achieves significant emissions reductions, but progress is tempered by the lack of financial support.

*For more details about the data sources used to prepare Figure 3.01, which includes over 40 years of historical data and additional scenarios from the National Grid, please refer to Appendix A.*



### 3.3 Carbon emissions and low carbon heat in London

#### 3.3.1 Current CO<sub>2</sub> emissions and carbon reduction targets

The Mayor aims for London to become a net zero carbon city by 2050 and has adopted a system of carbon budgets. Levels have been set so that within the third carbon budget period (2028-2032) London will aim to achieve a 60 per cent reduction in carbon dioxide emissions on 1990 levels. Around 80% of carbon emissions in the capital are associated with buildings.

Meeting the Mayor's zero carbon ambition by 2050 requires changes to the way we supply and use energy in new developments to ensure it is resource efficient and sourced from clean, low carbon and renewable sources. London will need to reduce its reliance on high carbon natural gas as a main energy source (for heat in particular) and increase use of local energy resources, including renewable and secondary heat sources, while ensuring air quality is not adversely affected.

#### 3.3.2 London Environment Strategy (2018)

Published in May 2018, the London Environment Strategy sets out the Mayor of London's approach to address a range of environmental challenges. It articulates what the issues are, the policy objectives to address them and sets out proposals.

##### ***Climate change and energy***

The London Environment Strategy stresses that, over the next two decades, dependence on natural gas must be reduced by increasing the use of low carbon heating (harnessing energy from water, ground and air using heat pumps) as well as capturing more of the heat wasted from our buildings and infrastructure and using heat networks in the most densely developed areas of the city to distribute it to London homes and workplaces. Demand on the electricity grid will likely increase due to the growing population and electrification of heat and transport, unless offset by reductions through energy efficiency and flexible electricity use. Smart technology will need to become an increasingly important part of managing London's energy system, helping to balance more intermittent supply of energy from renewables with more variable electricity demand from electric cars, or electric heating.

##### ***Air quality***

The London Environment Strategy identifies air quality as the most pressing environmental threat to the future of health in London, with two pollutants remaining a specific concern: particulate matters (PM<sub>10</sub>, PM<sub>2.5</sub> and black carbon) and nitrogen dioxide (NO<sub>2</sub>). The Mayor's strategic aim for 2050 is for London to have the best air quality of any major city, going beyond the requirements to protect human health and minimise inequalities. The Mayor's Energy for Londoners programme will support the transition from old inefficient gas boilers to ultra low NOx gas boilers and low carbon (and low-pollution) heating alternatives such as heat pumps.

### 3.3.3 Approach to low carbon heat in the London Plan

The London Plan is the overall strategic plan for London, setting out an integrated economic, environmental, transport and social framework for the development of London over the next 20–25 years. It includes a number of policies in relation to climate change. The approach to low carbon heat has evolved between the current London Plan (2016) and the Draft London Plan (2018). The policies which are most relevant to this study are set out below.

#### London Plan (2016)

##### **Policy 5.2 Minimising carbon dioxide emissions**

*A) Development proposals should make the fullest contribution to minimising carbon dioxide emissions in accordance with the following energy hierarchy:*

1. *Be lean: use less energy*
2. *Be clean: supply energy efficiently*
3. *Be green: use renewable energy*

*As a minimum, energy assessments should include the following details:*

*C) proposals to further reduce carbon dioxide emissions through the use of decentralised energy where feasible, such as district heating and cooling and combined heat and power (CHP)*

##### **Policy 5.6 Decentralised energy in development proposals**

*A) Development proposals should evaluate the feasibility of Combined Heat and Power (CHP) systems, and where a new CHP system is appropriate also examine opportunities to extend the system beyond the site boundary to adjacent sites.*

*B) Major development proposals should select energy systems in accordance with the following hierarchy:*

- 1 *Connection to existing heating or cooling networks;*
- 2 *Site wide CHP network;*
- 3 *Communal heating and cooling.*

#### Draft London Plan (showing minor suggested changes, July 2018)

##### **Policy SI2 Minimising greenhouse gas emissions**

*Major development should be net zero-carbon. This means reducing greenhouse gas emissions in operation and minimising both annual and peak energy demand in accordance with the following energy hierarchy:*

- a. *Be lean: use less energy and manage demand during operation.*
- b. *Be clean: exploit local energy resources (such as secondary heat) and supply energy efficiently and cleanly.*
- c. *Be green: maximise opportunities for renewable energy by producing, storing and using renewable energy on-site.*

**Policy S13 Energy infrastructure**

*D) Major development proposals within Heat Network Priority Areas should have a communal low-temperature heating system.*

*1. The heat source for the communal heating system should be selected in accordance with the following heating hierarchy:*

- a) connect to local existing or planned heat networks*
- b) use zero-emission or local secondary heat sources (in conjunction with heat pumps, if required)*
- c) use low emission combined heat and power (CHP) (only where there is a case for CHP to enable the delivery of an area-wide heat network)*
- d) use ultra-low NOx gas boilers.*

*2. CHP and ultra-low NOx gas boiler communal or district heating systems should be designed to ensure that they meet the requirements of policy S11 (A).*

*3. Where a heat network is planned but not yet in existence the development should be designed for connection at a later date.*

**Greater London Authority guidance on preparing energy assessments (2016)**

The GLA provides guidance for developers and their advisers on preparing energy assessments to accompany strategic planning applications. It guides applicants on choosing a policy compliant approach and how systems should be designed to allow for future heat network connection. The guidance also refers to heat pumps.

**3.3.4 The potential role of heat pumps in London**

The evolution of policy is consistent with the main options for low carbon heat outlined by the Committee on Climate Change, namely low carbon heat networks and heat pumps.

**Developments in Heat Network Priority Areas**

Low carbon heat networks have a key role to play in areas of high density of heat demand. They enable waste heat to be distributed to a wide range of end users and can minimise the space taken in individual apartments. However, as the electricity grid decarbonises, the carbon benefits of gas-fired Combined Heat and Power (CHP) significantly reduces as the electricity produced by CHP becomes higher carbon than that supplied by the national grid. This reduction in the carbon benefit, along with the need to reduce combustion in large cities for air quality reasons, mean that the heat generation for District Heating (DH) networks will need to evolve significantly compared to the current approach.

Fourth generation DH using low carbon sources and distributing heat at very low temperatures will be required and heat pumps can play a key role in these networks through their ability to extract and upgrade the warmth available from waste or environmental heat across the city. The higher temperature the heat source, the less energy is required to provide heating to end users.

Fig 3.02 outlines potential waste and environmental heat sources in London.

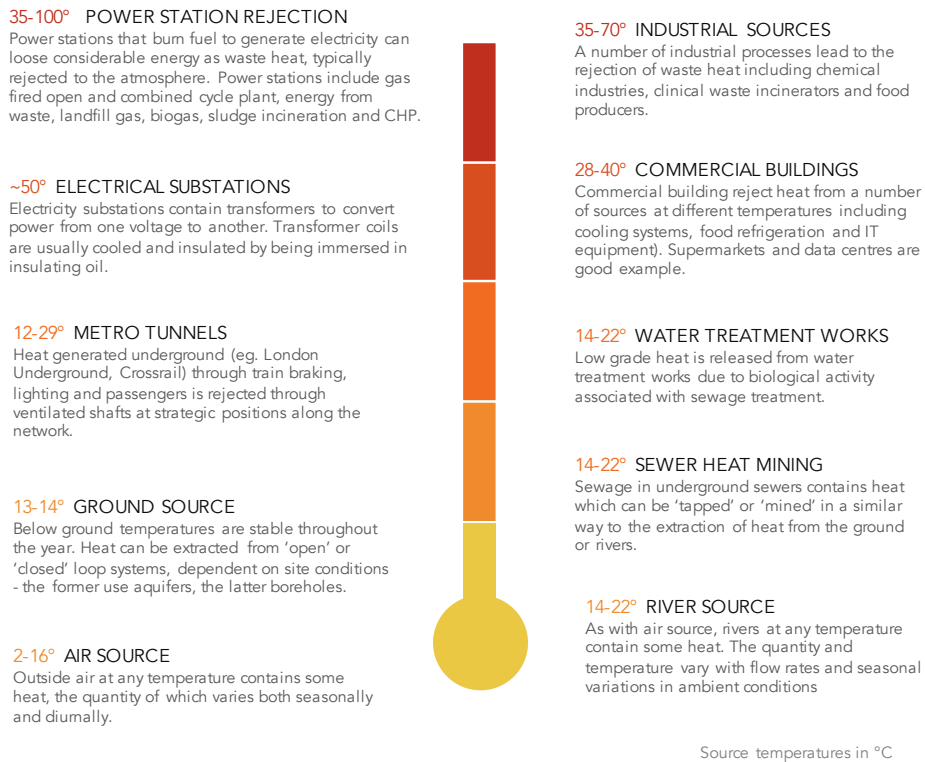

**Figure 3.02 – Sources of waste heat and associated temperatures (Source: Greater London Authority: Secondary Heat Study – London’s Zero Carbon Energy Resource)**

**Outside of Heat Network Priority Areas**

As it can be seen on Figure 3.02 above, there is a wide range in low carbon heat sources but they are not available across the whole of London. In the absence of a low carbon heat network, heat pumps have a different role to play: a low carbon and combustion free alternative to gas boilers.

**3.3.5 Heat pumps in London**

The Renewable Heat Incentive (RHI) data provides the total number of heat pump accreditations in London over the last 4 years. London has had 228 air source and 57 ground source heat pumps, but this only represents RHI eligible installations and excludes new buildings.

The Greater London Authority has produced a revised London Zero Carbon Pathway Tool which draws on extensive research of the building and energy system changes required to get to zero carbon conducted by Element Energy. It brings together existing and new evidence under one tool. Data can be visualised on a detailed interactive map for energy and emissions trajectories until 2050, including the impact of greater heat pump uptake. Three scenarios illustrated in Figure 3.03 have been considered:

- a 'low' uptake scenario, assuming very modest increase in the number of installations of heat pumps in new developments compared with the current number of installations;
- a 'medium' uptake scenario, assuming a very significant adoption of heat pump systems in London’s new developments;
- a 'high' uptake scenario, assuming an even greater adoption of heat pump systems in London’s new developments.

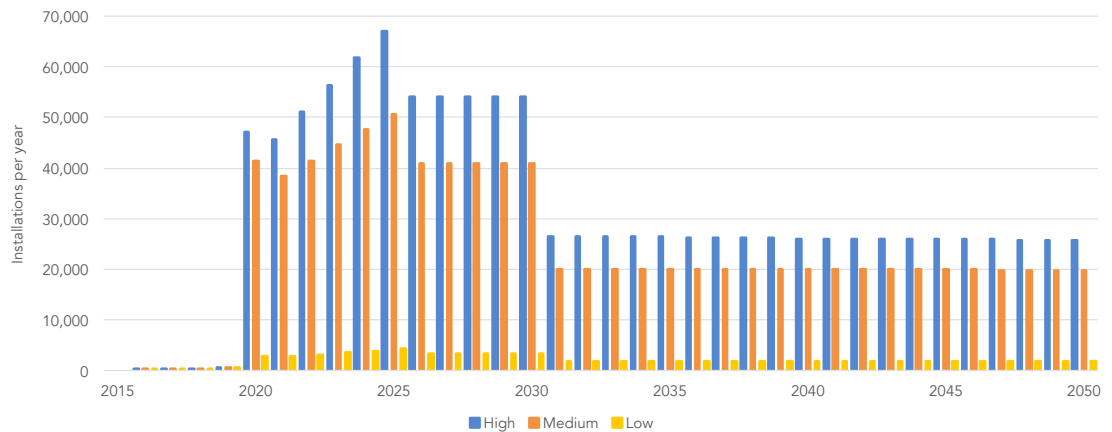

**Figure 3.03 – Heat pump uptake scenarios for London (Source: Greater London Authority)**

The energy systems analysis undertaken by Element indicates that heat pumps are likely to play a key role for the delivery of low carbon heat in all scenarios considered.

## 3.4 Thinking about the consumer

### 3.4.1 Mitigating fuel poverty and ensuring affordability of heat

The transition to a zero carbon London must not lead to a significant increase in energy costs for Londoners, particularly the most vulnerable. According to the latest available data, more than 335,000 households are affected by fuel poverty in London. Fuel poverty is caused by a combination of low income, poor energy efficiency and/or high energy prices.

Although energy efficiency is a very important consideration for fuel poverty as existing properties represent the vast majority of cases, the issue of affordability of heating in new build should remain at the forefront of any strategic decision regarding low carbon heat. As electricity decarbonises we should remember that it remains an expensive form of energy and that its prices may rise in the future. It will therefore be important to make sure that consumers using electricity for heat generation use efficient systems and use electricity when it is cheaper by building in sufficient thermal and electrical storage.

### 3.4.2 Concerns with heat pump systems

Specific concerns on heat pumps from consumers (evidenced through Etude project experience and literature review) include:

- High energy costs in ‘mis-application’ cases, i.e. when the ‘wrong’ type of heat pump has been installed in one or several properties (e.g. exhaust air source heat pump in large existing property, poor evaluation of likely heat demand);
- Higher levels of complexity of some systems, which make it difficult for the end-user to understand whether the system is operating as efficiently as it should;
- Difficulties associated with maintenance due to the low number of companies able to maintain a heat pump compared with a more traditional heating system.

It is crucially important for the building industry to acknowledge and address these concerns.

# 4.0

## SETTING THE SCENE

---

There is a significant variety of heat pumps: different **heat sources** (e.g. air, ground), **scales** (e.g. individual unit, medium/communal system, large scale for district heating) and **ways to distribute heat** to where it is needed (e.g. water or refrigerant). It is very important to appreciate the diversity of heat pump systems.

And heat pumps are very different from gas boilers. Their efficiency is very dependent on the heat supply temperature, which should be lower than conventional heat distribution systems. It is also influenced by the strategy used to generate domestic hot water. A widespread uptake of heat pumps would require a much greater emphasis on these two aspects and an evolution of 'business as usual' approaches to building services design.

As accurate assumptions on efficiencies are crucial to a robust assessment of carbon emissions and energy cost savings, we have done research in this area. This informed our carbon content of heat analysis which confirms that heat pumps have the potential to be low carbon heat solutions.

## 4.0 SETTING THE SCENE

A heat pump uses electricity and a refrigerant to extract heat from a source (air, ground water) and produce useful heat more efficiently than direct electric heating.

The variety of systems (both in terms of scale and types) is significant and often confuses the debate as some advantages or concerns only apply to some types. For example, discussions on actual efficiencies have mainly focused on small scale air source heat pumps, safety considerations primarily apply to refrigerant-based distribution, maintenance concerns generally apply to systems requiring a heat pump in each unit, etc.

One of the key messages of this overview of heat pumps and the role they can play to deliver low carbon heat in London is the sheer variety of systems. Therefore, and in order to enable a clear appraisal, this section proposes a simple taxonomy.

It also focuses on three key considerations:

- How efficient are the different types of heat pumps?
- How can domestic hot water be generated?
- Which carbon content(s) of heat would be appropriate for heat pumps?

The section is concluded by a brief summary of the literature review undertaken as part of this study.

### 4.1 Heat pump: basic principle

Although their heat source, scale and type can vary, their operating principle is the same. The name 'heat pump' communicates this principle well: in the same way that a pump is used to move a fluid, a heat pump is used to move thermal energy from a heat source (e.g. air or ground) to a heat sink (e.g. hot water for radiators) using electricity.

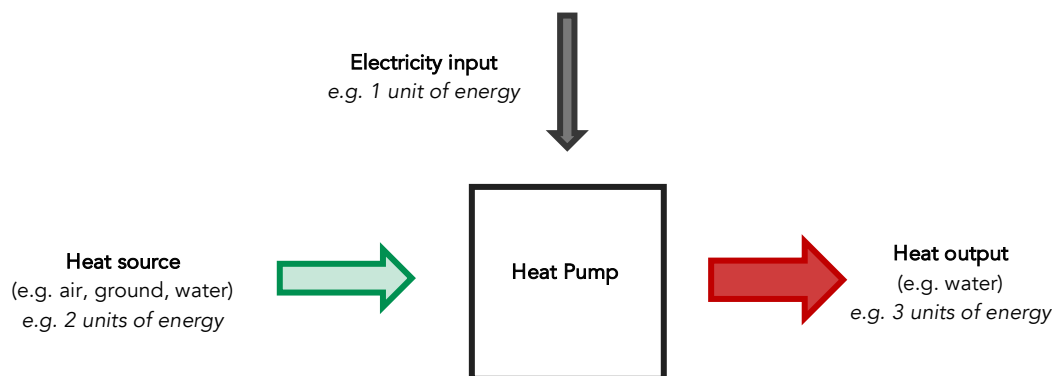

Figure 4.01 – General principle of a heat pump

The heat source is generally free and renewable, and heat pumps can achieve high levels of efficiency (ratio between heat output and electricity input).

## 4.2 Heat pump types

Given the variety of heat pump systems and in order to enable a clear appraisal of their impact (e.g. cost, space, noise), a heat pump taxonomy is proposed. It categorises heat pump systems not only by heat source type (e.g. air, ground) but also by scale (e.g. small, medium, large). The taxonomy concentrates on the most common systems but other types are also mentioned in section 4.2.3.

### 4.2.1 Proposed heat pump taxonomy

The different types of heat pumps are summarised in the proposed taxonomy below and the more detailed tables in Appendix B. They relate to the three key scales we have considered:

- **Small scale / individual heat pumps** (0-20 kW / 0-5 kg of refrigerants): these heat pumps are individual installations (e.g. in each dwelling). They are the heat pump equivalent of an individual gas boiler.
- **Medium scale / communal heat pumps** (20-170 kW / 5-50 kg of refrigerants): these heat pumps can be the heating system of a non-domestic building (e.g. school or office building) or the communal heating system of an apartment block. They include individual heat pumps working off a communal ground loop.
- **Large scale / district heat pumps** (>170 kW / >50 kg of refrigerants): these heat pumps can serve large non-domestic buildings (e.g. office buildings) or be integrated into the energy centre of a district heating network.

For more details about the different types of heat pumps, please also refer to Appendix B.

### 4.2.2 Non-conventional heat pumps

**High temperature heat pumps** are defined as heat pumps (of any source) that can achieve water flow temperatures of 65°C<sup>6</sup> or above. They are typically used to heat large inefficient properties where their ability to heat water to higher temperatures and their compatibility with existing heat distribution systems is an advantage. As existing buildings are not covered in this study, and they are less efficient, this type of heat pumps has not been considered.

**Gas driven heat pumps** (absorption and adsorption) use gas combustion to drive the heat exchange cycle. They are at a very early stage of deployment particularly in the domestic sector, with only a handful of manufacturers in the UK. Ammonia and water are typically used in place of a refrigerant, with ammonia acting as the heat absorber which condenses with water to release heat. Although ammonia has no impact on ozone depletion potential, it is toxic and flammable. This type of heat pump has not been considered as it uses gas as its main fuel.

---

<sup>6</sup> According to the performance standard BS EN 14511:2013, an output temperature of 55°C is defined as “high temperature”, and 65°C is “very high temperature”. The next revision of the standard is likely to re-define “high temperature” range to be 65°C.



## 4.3 Efficiency of heat pumps

### 4.3.1 Which efficiency metric should be used?

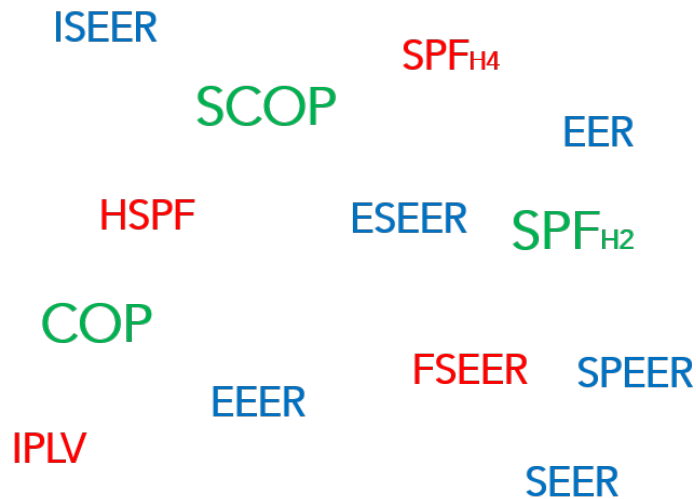

Figure 4.02 – Heat pump efficiency metrics used (correctly and incorrectly)

In the absence of global industry standardisation, over a dozen measures of heat pump efficiency have developed over time to fulfil various requirements around the world. Many of these efficiency metrics are not directly comparable with one another. Some are specific to heating, while others are specific to cooling. Even within a single measure of efficiency, there may be several subsets depending on which parts of the heat pump system are included in the calculation. This can create confusion.

Appendix D provides a detailed technical overview of the more common efficiency standards in use today. In summary the use of the following efficiency metrics is recommended and has been adopted within the study:

1. **Manufacturers' reported efficiencies based on Coefficients of Performance (COP).** The COP provides an indication of efficiency under standard test conditions for a fixed heat source temperature and heat distribution temperature<sup>7</sup>.
2. **Manufacturers' reported efficiencies based on Seasonal Coefficients of Performance (SCOP).** The SCOP uses COP data to calculate the annual average efficiency for a heat pump<sup>8</sup>.
3. **Seasonal Performance Factors (SPF) from heat pump field trials<sup>9</sup>.** The SPF is usually calculated using empirical data from real-world field trials of heat pumps.

<sup>7</sup> Tested under EN14511:2013.

<sup>8</sup> Calculated under EN14825:2016. Three different climates are defined in the standard.

<sup>9</sup> Based on a H2 boundary condition, as defined by SEPAMO-Build. See Appendix D for further details.

### 4.3.2 Efficiency - looking at the small print

The efficiency characteristics of heat pumps are also different to traditional heating systems: they are influenced by a wide range of factors, which are outlined in detail in Appendices C and D.

The two most important factors that affect efficiency are the **heat source temperature** and the **heat distribution system temperature** (or heat supply temperature). The closer these temperatures are to one another, the higher the efficiency of the heat pump. This relationship is shown clearly in Figure 4.03, which compares the Coefficient of Performance, a common measure of efficiency under steady state conditions, with distribution temperature for typical air and ground source heat pumps.

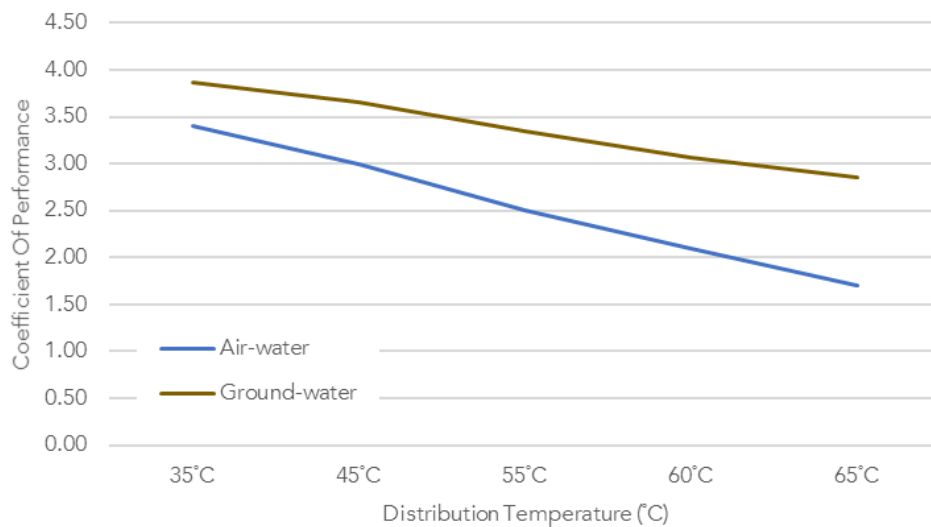

**Figure 4.03 – Indicative Coefficient of Performance (COP) variation with heat distribution temperature for a given source temperature for air source and ground source heat pumps**

Importantly, these temperatures are often influenced by heat pump system design, installation, commissioning and operation. The importance of minimising this temperature difference and how best to achieve it in practice must therefore be clearly understood by designers, installers and end-users if heat pumps are to operate efficiently.

This evidence base therefore requires a reliable measure of heat pump efficiency to develop accurate energy, carbon and cost calculations.

### 4.3.3 Efficiencies used in this study and justification

A range of data sources were used to determine a realistic range of COPs and SCOPs for use in this study. The data sources and ranges of performance included several field trials in the UK and Europe, values used by public authorities and manufacturers' test data. COPs have intentionally been included in addition to SCOPs to avoid using average values where possible by accounting for distribution flow temperature.

Table 4.01 on the following page has been prepared to summarise the analysis of these data sources.

SPF <sub>H2</sub> SPF <sub>H3</sub> SPF <sub>H4+</sub>	Data Source	Heat Pump Type			Confidence
		Air-air	Air-water	Ground-water	
	Field Trials				
	EST Field Trials 1		1.20 – 2.20	1.55 – 3.47	*
	EST Field Trials 2		2.00 – 3.60	2.00 – 3.82	**
	RHPP Detailed Analysis Report*		2.33 – 2.95	2.81 – 3.14	**
	Fraunhofer WP-Effizienz		2.50 - 3.60	3.00 – 5.20	***
	Fraunhofer WP im Gebäudebestand		2.20 – 3.10	2.80 – 3.60	***
	SEPEMO-Build	3.30 - 3.80	3.00+	4.00+	***
	Public Authority Decisions (EU/UK)				
	Commission decision 2013/114/EU	2.60	2.60	3.50	**
	DECC RHI Evidence Report RAAHP's	2.80	2.60	2.90	**
	Manufacturer Test Data (EN14825:2016)				
	Daikin	3.50 - 5.90	2.60 - 4.39		**
	Mitsubishi	3.90 - 5.20	3.19 – 4.12	3.37 – 5.09	**
	Panasonic	3.80 – 4.90			**
	Kensa			2.94 – 4.69	**
	Nibe	3.82 - 4.16	3.75 - 5.05	3.30 – 5.20	**

**Table 4.01 – Range of reported heat pump efficiency data.**

Please refer to Appendix C for an explanation on the different system boundaries H2, H3 and H4 and to Appendix E for additional information on the data sources. Please note that the RHPP\* data should be treated with care as its robustness has been questioned.

Based on the data summarised in the above table 4.01, the following efficiencies in table 4.02 have been assumed in this study. For clarity, they have been translated into % (e.g. SCOP of 2.0 is equivalent to a seasonal efficiency of 200%) in order to provide a direct comparison with other systems e.g. gas boilers. The table illustrates one of the key messages of this study: the variability of heat pump efficiencies with flow temperature and the need to understand them in order to assess them objectively.

Heat pump type	Efficiency at specific flow temperature (SCOP)					Typical average efficiency
	35°C	45°C	55°C	60°C	65°C	
air-air	300%	-	-	-	-	300%
air-water	340%	300%	250%	210%	170%	260%
ground-water	385%	365%	335%	305%	285%	320%

**Table 4.02 – Heat pump efficiencies (SCOP) used in this study<sup>10</sup>**

<sup>10</sup> These seasonal performance factors assume the SEPEMO-Build SPF<sub>H2</sub> system boundary.

#### 4.4 Approach to hot water

The efficient generation of domestic hot water (DHW) by heat pumps for sanitary purposes can be challenging. The main issue revolves around the need for DHW to be distributed so it reaches a temperature of at least 50°C to all outlets within 1 minute (55°C in healthcare buildings), requiring storage at a temperature of at least 60°C. This is a strict requirement set out by the Health & Safety Executive in the *Legionnaire's disease Technical Guidance Part 2: The Control of Legionella bacteria in hot and cold water systems*.

Heat pumps work most efficiently when the temperature difference between the heat source and the hot water being produced does not exceed 30-40°C, a temperature range well suited to producing low temperature hot water for space heating. The temperature difference associated with generating DHW is particularly sensitive to both source temperature and DHW system architecture and is usually higher than this optimal range in the UK climate.

As an example, an air source heat pump delivering water to a district heating system that will be used for DHW and space heating must provide water at over 65°C to allow for temperature drop across the network due to distribution losses. On a cold winter day with an air temperature of -5°C the heat pump will have to work against a temperature difference of 70°C. Conversely, a small air source heat pump delivering hot water at 60°C directly to a hot water tank in a dwelling at a milder outdoor temperature of 15°C would experience a much smaller temperature difference of 45°C.

The first system would be unlikely to achieve a respectable overall efficiency. Once distribution and storage losses are taken into account the heat pump-based solution may provide little advantage in overall energy, cost and carbon terms relative to an instantaneous electric water heating system, which benefits from elimination of these losses. The second system would be able to achieve a more respectable efficiency and would be more likely to justify the additional cost and complexity of a heat pump based DHW system.

These examples have been used to highlight the complexities associated with determining whether heat pumps are well-suited for the generation of DHW. Generally speaking, they are less well-suited to systems that require storage over 60°C and/or incur significant distribution losses. A range of DHW system architectures exist which could potentially address these issues. They would all require a single heat pump system and include, but are not limited to:

1. Heat pumps that provide hot water to a DHW storage tank with minimal distribution losses and a storage temperature close to 60°C. This could be achieved in practice either by a well-designed monobloc unit or VRF based system;
2. Communal or district heating system operating at flow temperatures below 60°C, if instantaneous heat interface units can be used to mitigate legionnaires risks that would traditionally be associated with DHW storage in each unit. Optimal system architecture would even separate heating from DHW generation so that heating can benefit from outdoor weather compensation which keeps output temperatures as low as possible;
3. Use of instantaneous electric water heating with water efficient fittings, efficient appliances and waste water heat recovery, to achieve similar savings to heat pumps. This typically suits buildings with relatively low demand for DHW such as commercial buildings but can also be appropriate for other typologies if DHW demand is decreased sufficiently.

This section focuses on communal systems. It should be noted that most individual heat pumps have been installed in the UK with a storage tank.

### 4.5 The importance of flow and return temperatures

As highlighted in the last two sections, the efficiency of heat pumps cannot be considered in isolation from the heat distribution system they will supply. Heat pumps are not a like-for-like replacement technology for gas boilers and gas CHP. In order for them to be as efficient as possible they should supply heat distribution systems at a low temperature. Mechanical design must evolve and adapt. See section 7.2 for further details.

If the issues of hot water generation and of flow and return temperatures are not addressed, there is a significant risk that a performance gap will be introduced, with heat pump systems not delivering the carbon and cost savings they are able to. The Greater London Authority should recommend and monitor good practice in this area.

### 4.6 Towards low carbon heat – Determining the carbon content of heat

Accurately determining the carbon content of heat delivered by heat pumps relative to gas-fired CHP based heating systems is necessary to calculate carbon emissions from proposed developments. A comparison with a communal gas boiler is also useful as a reference point.

As shown in Figure 4.04 on the following page, individual heat pumps provide substantially lower carbon heat than gas-fired CHP and individual gas boilers when used for either space heating or domestic hot water, based on the proposed SAP 2019 emission factor (i.e. 302 gCO<sub>2</sub>/kWh). The carbon content of the heat provided by a district heating system using a heat pump and gas boiler is only slightly lower than gas-fired CHP due to the lower efficiency of the heat pump when providing water at a hotter temperature, the relatively high carbon heat from the gas boiler and the additional distribution losses relative to the individual heat pump scenarios.

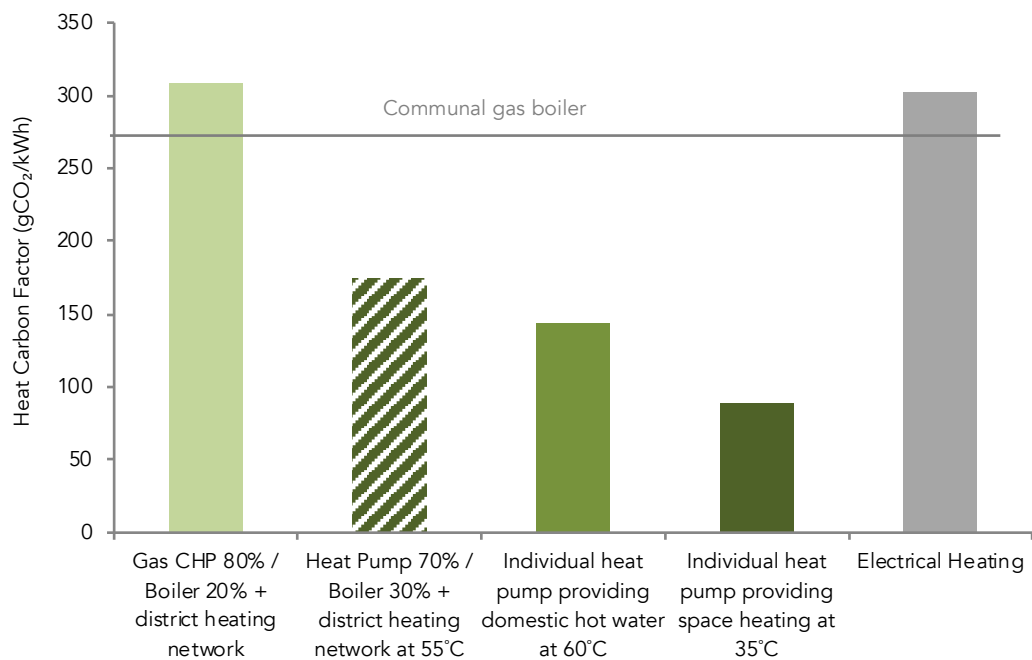

Figure 4.04 – Carbon factor of heat based on 2019 marginal grid emission factor of 302 gCO<sub>2</sub>/kWh

This analysis assumes a baseline district heating system with distribution losses of 20%, where 80% of the heat is provided by a gas-fired CHP unit (a very high contribution from CHP), with the remaining heat provided by a large gas boiler. The heat pump based district heating system obtains 70% of its heat from a heat pump and 30% from a large gas boiler. It is assumed that a waste heat source is used in conjunction with a 4<sup>th</sup> generation district heating network operating at 55°C enabling the heat pump to achieve a 335% efficiency. Domestic hot water is provided by instantaneous heat interface units to avoid legionnaires issues associated with storage below 60°C. For comparison, the carbon content of heat is also shown for individual heat pumps providing domestic hot water at 60°C and space heating at 35°C, operating at efficiencies of 210% and 340% respectively.

The long-term trends in heat carbon factors are clear in Figure 4.05, which is based on projected marginal grid emissions factors from HM Treasury’s Green Book. Heat pumps offer an immediate and significant reduction in the carbon content of heat today and this advantage increases substantially in the future as the electricity grid decarbonises.

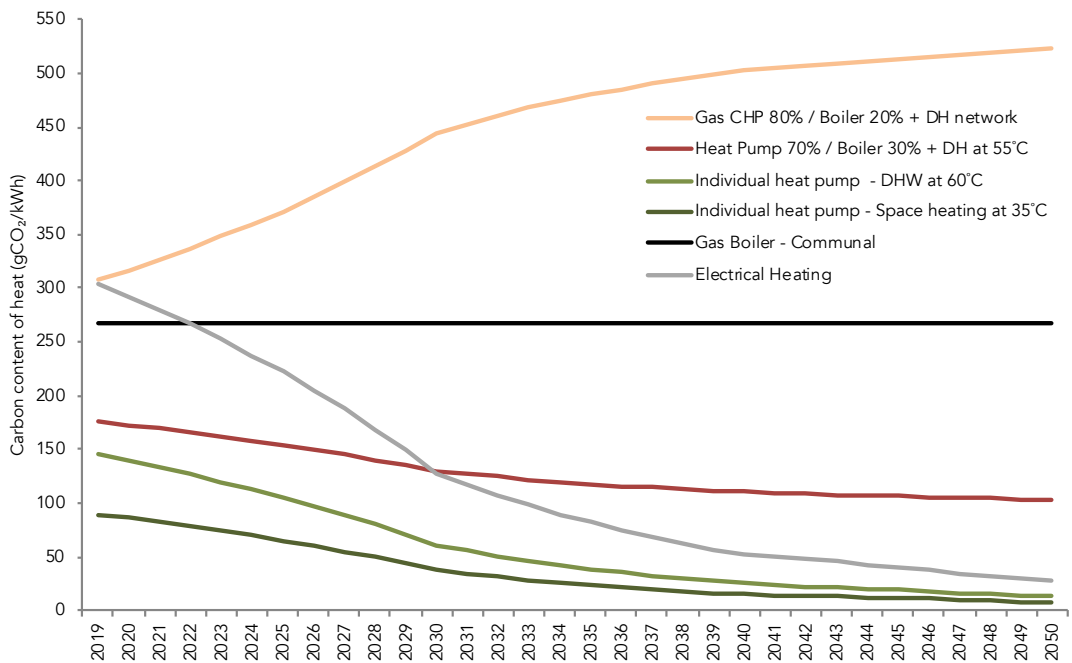

Figure 4.05 – Projected carbon factor of heat based on HM Treasury Green Book marginal emission factors

One consequence of performing carbon calculations for new developments using a grid emissions factor of 302 gCO<sub>2</sub>/kWh is that over a 15-year period, results underestimate the emissions from gas-fired CHP based heating systems by around 28% and overestimate the emissions from heat pump based heating systems by 40%. The reason for this is that the grid emissions factor is predicted to reduce significantly in the future and will be much lower than 302 gCO<sub>2</sub>/kWh on average over the first 15 years of a new building’s lifetime (e.g. SAP 10 proposed 233 gCO<sub>2</sub>/kWh). Please refer to Appendix G for further details.

#### 4.7 Air quality is also a key driver

A significant benefit of heat pumps over conventional boilers and gas-fired CHP is that there is no combustion at source (combustion of gas emits nitrous oxides). Beside the direct advantages (safety), technical advantages (e.g. no need for flues) this is very beneficial for cities like London with poor levels of air quality.

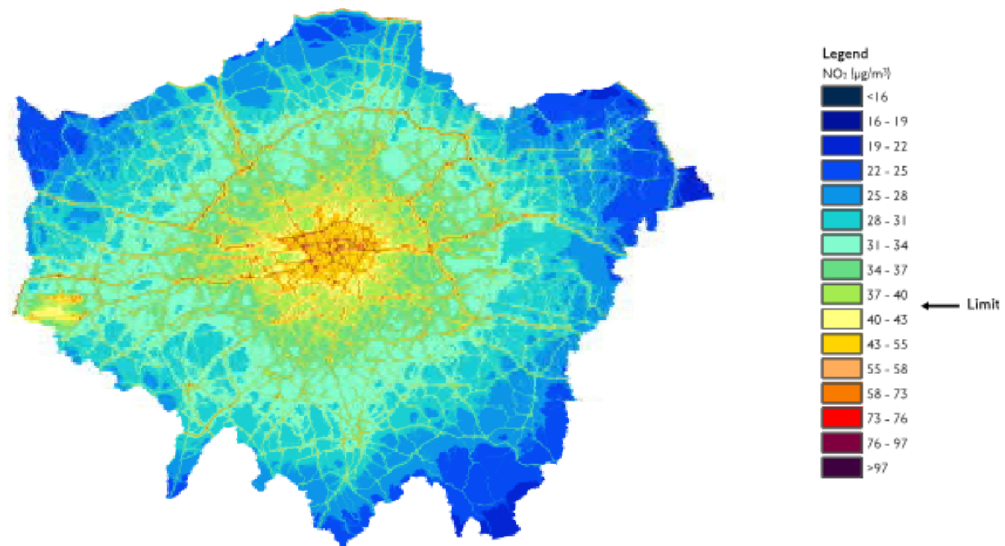

Figure 4.06 Annual mean NO<sub>2</sub> concentrations in London (Source: GLA (2017) LAEI 2013 update)

Maximising co-benefits between air quality and climate change policies is one of the Mayor of London's key objectives. In particular, while combined heat and power systems (CHP) can have benefits in terms of carbon emissions over gas boilers, gas engine CHP plant usually gives rise to higher emissions of NO<sub>x</sub> emissions than ultra-low NO<sub>x</sub> gas boilers, even when abatement equipment is used. In his draft London Plan the Mayor introduces a heating hierarchy that will promote cleaner heating solutions such as those based on secondary heat.

#### 4.8 Literature review

A literature review was undertaken. There are a vast number of publicly available reports that cover several considerations (e.g. technical, performance, consumer, government initiatives) in various contexts. Findings of the literature review undertaken as part of this study have informed sections of this report but a very short summary of the key messages emanating from the reports is also summarised below and a brief introduction to each key report can be found in Appendix H.

Key findings from this review were:

- Heat pumps can provide low carbon and affordable heat with a good efficiency, provided that they are properly designed and installed.
- Low heat supply temperature is key to maximising heat pump efficiency.
- A smart grid can potentially manage peak electricity demands imposed by heat pumps and the heat pumps could help to reduce these peaks through demand side management.
- Consumers’ confidence/awareness acts as a barrier to deployment, despite generally positive consumers feedback from field trials.

Some barriers to heat pump deployment were highlighted in various reports.

Consumer	Technical
Consumer confidence / awareness / trust	Noise
Aesthetics	Space
High up-front cost	Speed of installation
Uncertainty over performance/savings	Shortage of skills in supply chain (leading to poor specification / installation)
Readily accessible and low cost gas network	Compatibility with existing heating systems

**Table 4.03 - Potential barriers to heat pump uptake from the literature review**

#### 4.9 Heating our buildings: a historical perspective

The way we heat our buildings has always evolved. If we consider the changes over long periods of time, we can try to understand the reasons by grouping them in two broad categories:

1. **Type, availability and affordability of energy source:** wood, coal, paraffin, oil, natural gas all became, in turn the dominant energy source for heat in buildings. The trends affecting this were generally very important and have a historical significance, both in terms of technical progress and economics. Often the dominant form of energy available at the time ended up being used to heat buildings (with the energy source used for lighting often a sign of things to come for heating). This suggests that electricity is likely to become a growing source of energy for heat in the 21<sup>st</sup> century. Since the invention of the light bulb in the late 19<sup>th</sup> century, it has consistently become more widely used.
2. **Distribution and emission of heat:** the trends affecting this are less powerful than the first category and have more to do with how technical innovation enabled them. Their wide adoption was triggered by the benefits they brought: for example avoiding smoke associated with fire (which led to the development of chimneys in the thirteenth century), avoiding fires altogether (which was enabled by the use of steam in the industrial revolution), improving comfort (with the first forms of central heating in the 19<sup>th</sup> century) and then replacing steam which increased safety and durability (with the development of hot water distribution in the 20<sup>th</sup> century). Strategic societal benefits of systems from a local or national point of view (e.g. air quality, CO<sub>2</sub> emissions) are more important drivers now than they have been historically.

It is important to note that these changes have always happened over long periods of time. This is illustrated by the graph below which shows the market penetration of central heating in the UK housing stock: it took approximately 40 years for central heating to become the norm in existing UK homes.



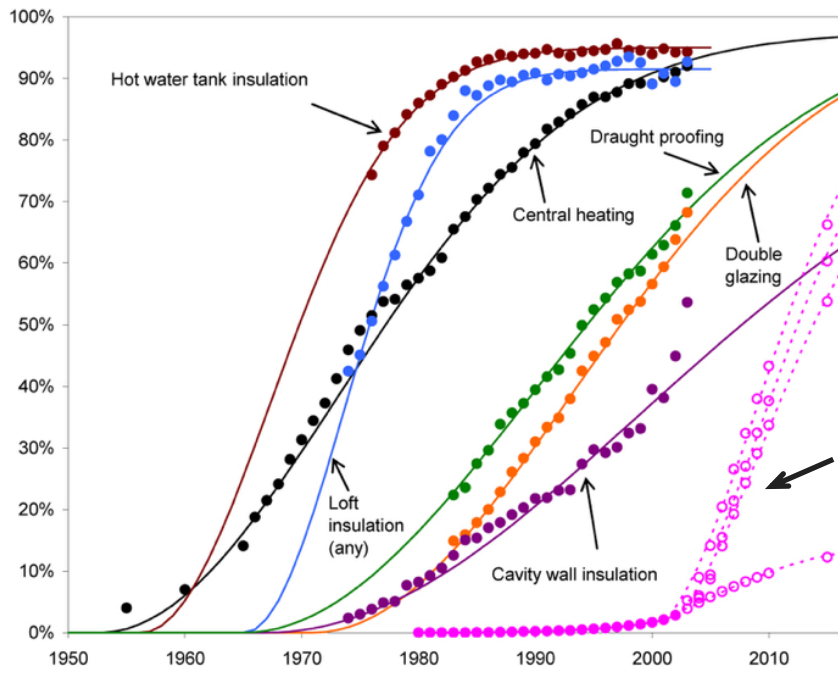

Figure 4.07 Market penetration of various measures in the UK housing stock (Source: BRE report BR435)

Although the image above can suggest that the pace of change can be slow, it is also important to realise that some of the technical challenges associated with some of them have been considerable. For example, retrofitting a gas supply in all existing apartment buildings and installing an individual gas boiler presented significant challenges. The main message is that change happens, even slowly and despite challenges.

The benefit of this historical perspective is to demonstrate that approaches to heating can and will change, despite challenges. It however also suggests that a very high market penetration of heat pumps in London within the next 5-10 years in existing homes is unlikely.

New buildings offer huge potential for market penetration of heat pumps. The Mayor's London Plan encourages low carbon and clean heating solutions, which can be delivered using technologies such as heat pumps.

# 5.0

## HEAT PUMPS : MARKET REVIEW

---

A review of the European and domestic markets for heat pumps revealed that the adoption of heat pumps in the UK lags behind many other countries.

In Norway, one third of households have a heat pump and they represent 95% of heating systems in new homes. In France, the number of heat pumps sold each year is 8-10 times higher than here, and approximately the volume required to achieve the uptake of heat pumps by 2030 outlined by the Committee on Climate Change.

In order to gather more qualitative and London specific data, seven online surveys were sent to suppliers, installers, developers, housing associations, local authorities and industry professionals. More than 80 people responded, which provides the GLA with a very valuable mosaic of insights and recommendations.

Although many challenges are highlighted, more than two thirds of the respondents (excluding suppliers) believe that heat pumps will become the main heating system for our buildings either in the near or longer term future.

## 5.0 HEAT PUMPS – MARKET REVIEW

This section summarises the heat pump market at a European level and a UK level, which provides points of comparison and enables the understanding of the volume of heat pump sales and their approximate market penetration rate in new buildings.

Seven surveys were sent to various stakeholders, from heat pump suppliers and installers to developers, housing associations, London Boroughs energy officers and engineers. 81 people kindly responded to the study: although the volume of respondents is therefore not statistically significant, the feedback and recommendations to the GLA are invaluable.

The section is concluded by a shortlist of case studies where heat pumps have been selected.

### 5.1 Heat pumps in other European countries

The European Heat Pump Association (EHPA) publishes statistics on the European heat pump market every year. The 2016 and 2017 reports were analysed as part of this study and are summarised below.

#### 5.1.1 Data sources

Market data summarised in these reports was gathered via questionnaires submitted to national heat pump associations, statistics bureaus and research facilities. It should be noted that the sales figures for air-to-air units in the UK and other average climate zones are not included.

#### 5.1.2 Market size and penetration rate

In 2016, there were approximately 1 million heat pump units sold in the EU.

This represented a growth of 13% compared with the previous year and was a third consecutive year of growth. Given that the overall construction industry grew less than 1% over the same period, the growth rate seems to suggest that the rate of market penetration of heat pumps in new buildings is increasing. The market is dominated by small-scale systems (<20kW) which account for more than 90% of the sales.

In terms of number of units sold in each country per year, there are three countries where more than 100,000 units were sold in 2016:

- France (>220,000 units)
- Italy (>180,000 units)
- Sweden (>100,000 units)

This is significantly more than the 20,000 units sold in the UK. Normalised against the number of households, the difference between the UK market and other countries is significant (e.g. the UK registers one tenth of heat pump units sold in France).

The 1,000,000 new heat pump units sold in the EU as a whole brought the total number of units to 9,500,000 in 2016 (this figure was only 1,100,000 in 2005). This is estimated to represent approximately 4% of the building stock and a total aggregated thermal capacity of 82.7 GW.

Generally Nordic countries have the highest number of heat pumps. In particular, Norway has the highest share of heat pumps proportion with more than one third of all household equipped with a heat pump. 95% of new heating systems are heat pumps. The UK is at the other end of the scale with less than 1% of new heating systems. Key factors influencing the uptake of heat pumps include the availability of gas (which is less widely available in some countries than in the UK), the price relativities between fuels (the ratio between the price of electricity and gas is comparatively higher in the UK) and the policy framework (some countries are promoting heat pumps much more actively).

### 5.1.3 Rates of growth varies differ among EU countries

Generally, the number of heat pump units sold has consistently increased over the 2005-2016 period with the exception of two significant falls in 2009 and 2012, which is likely to be associated with the consequences of the financial crisis on the European economy.

The rates of growth for the number of heat pumps sold in the EU differ significantly. While some countries experience significant rates of growth (e.g. the Netherlands, Italy and Ireland achieved growth rates of 20%+), growth in other countries has been much slower so far.

Interestingly nearly 90% of the total sales have occurred in the top 10 EU countries for heat pumps, suggesting that some markets are more mature than others with building regulations generally a key driver for heat pumps.

### 5.1.4 Types of heat pumps

Heat pumps tend to be deployed first in new build small projects (individual homes, small apartment blocks), then as a retrofit solution for existing homes and later in larger developments.

The three main technologies used are air-to-air systems (50% of units sold) followed by air-to-water systems (40% of units sold) and ground-to-water systems (10% of units sold). These proportions have been fairly constant over the last 10 years with the proportion of air-to-water systems increasing.

Air source heat pumps, exhaust air heat pumps and combined heat pump/ventilation systems are all expected to gain market share. Generally, the EHPA reports state that air is and will remain the dominant energy source for heat pumps.

Larger heat pumps (>20kW) are expected to gain market share over time with ground-water source and water-source systems likely to represent the majority of systems (although air source is expected to play a role in this segment too).

More generally, the use of heat pumps for the generation of hot water has consistently and significantly increased since 2010.

### 5.1.5 Production of heat pumps

France, Sweden, Germany and Italy manufacture the largest number of heat pumps.

Cost and efficiency improvements can be expected as more components are specifically manufactured for heat pumps. Examples include compressors, 3-way valves and control systems.

### 5.1.6 Technical points

Although it is not their main purpose, the EHPA reports also discuss several technical points. The main points relevant to this study are summarised below.

- **Noise.** Fan noise is a key issue for air source units. Research is currently addressing this in terms of reducing sound emission levels and improving understanding of installation location on sound emissions.
- **Heat pumps and smart grid.** Under Ecodesign lot 33, a study was undertaken into potential for smart appliances. Heating, ventilation and cooling were identified as the area having greatest potential for demand response.
- **Thermal storage.** Coupled to heat pumps, thermal storage provides an available and important means of energy storage.
- **Ecolabels.** The label currently in force for heat pumps (<100 kW) cover various aspects including safety of components, consumer information, installer training, sound level, energy efficiency, Global Warming Potential and availability of spare parts. In the future it may also cover issues such as reparability and demand response.

## 5.2 The heat pump market in the UK

The Building Services Research and Information Association (BSRIA) publishes a market report every year. The 2017 and 2018 reports were purchased as part of this study and are summarised below. Please note that although the whole reports have influenced this study, some numbers and information were redacted for the public version at BSRIA's request.

### 5.2.1 Data sources

Market data summarised in the 2018 report is based on data from 2016 and 2017 (estimates). Forecasts up to 2022 are included based on BSRIA's best assumptions.

It should be noted that UK air-to-air units are not included (they were not included in the EHPA market reports for the UK either).

### 5.2.2 Total number of heat pump units sold per year

The total number of heat pump units sold per year in the UK is relatively stable but has increased in 2017. It represents approximately 20,000-22,000 units per year (excluding air-to-air units).

Annual decreases in the number of units sold (e.g. from 2015 to 2016) can be explained by the low price of oil, the increase of the VAT rate to 20%, the lack of MCS accredited installers, uncertainty over policy decisions (e.g. consultation on the Renewable Heat Incentive) and the decreasing support for renewable energy at the building scale.

Two other key reasons appear to be a lack of incentivisation through building regulations (which currently use an out-dated carbon factor in Part L assessments) and a general lack of understanding of environmental and cost benefits in the longer term. Product awareness has increased greatly in recent years.

### 5.2.3 Heat pumps in the context of other heating systems in the UK

83% of all homes in the UK are heated by gas with individual gas boilers the most common solution by far. The majority of other homes are heated by electric storage heaters, oil and LPG. The number of homes served by heat pumps in the UK is very limited. They do, however, represent a growing proportion of the new build and retrofit market.

### 5.2.4 Types of buildings

Approximately 48% of all heat pumps are sold in the 'existing/retrofit' market and 52% of them (i.e. approximately 11,500 heat pumps per year) are sold to the new build sector. Residential applications represent the vast majority of the market. Focusing on new residential units only, we can estimate the number of heat pumps at approximately 10,500 new units per year. Assuming an average number of new residential units completed per year of 175,000<sup>11</sup>, this represents a small proportion of the total number of new residential units. It should also be noted that the vast majority of heat pumps are sold for individual dwellings. Fewer than 160 systems of more than 20kW are installed annually in apartment buildings.

As far as other sectors are concerned, the number of heat pumps installed in non-residential buildings in 2017 was approximately 1,000. The data available for these sectors is not as accessible as the number of residential units but the applications are known: offices, education buildings, hotels and industrial buildings seem to represent the main applications of heat pumps with between 130 and 170 systems of more than 20kW each installed annually. It is clear that the number of heat pump installations per year in apartment buildings and non-residential buildings in the UK is still small. However, 35% of the 115 major mixed-use and non-domestic applications reviewed by the GLA in 2017 included a heat pump system which demonstrates that their number is growing<sup>12</sup>.

### 5.2.5 Types of heat pumps

Air source heat pumps dominate the market.

Ground source water-to-water systems represent 11% of all units sold (approx. 2,350 units per year).

The number of hybrid heat pumps (heat pumps incorporating a gas combi boiler) sold is very limited (approx. 400 units per year) They seem to be used primarily for existing buildings which require the additional capacity for space heating purposes.

Only 4% of the air source systems are over 20kW whereas this proportion rises to 20% for ground source heat pumps.

### 5.2.6 The future

Low temperature heat pumps dominate the market. Only 2-3% of air source heat pump systems are 'high temperature heat pumps' supplying temperature up to 80°C. This suggests that although this application is possible, low temperature should become the norm (both for district heating and building heating) to facilitate the uptake of heat pumps. Interestingly, the report points out that heat

---

<sup>11</sup> <https://fullfact.org/economy/house-building-england/>

<sup>12</sup> In 2017, In London, 41 of the 129 major development applications reviewed by the Mayor included a heat pump system. The majority of them were proposed for non-residential applications.

pumps sold in the UK are increasingly 'Smart Grid ready'. It states that these heat pumps '*have certain control capacities, monitoring and dialogue capabilities, that allow the utilities to manage them depending on the demand and supply capacity*'. As incentives for services that help network operators better balance supply and demand grow and the technological ability to do so increases, this could become a very important competitive advantage of heat pumps compared with other heating systems. This is particularly true if battery storage becomes more common in buildings.

### 5.3 Engagement with the supply chain and the building industry

The heat pump market reports summarised in the previous sections demonstrate that heat pumps currently play a role in delivering low carbon heat in the UK. However, they also show that their levels of market penetration are not very high, particularly compared with other comparable European countries.

Given their potential role in the future, and in order to inform the view of the GLA on heat pumps, our research provides a mosaic of perspectives on heat pumps.

#### 5.3.1 Process

Seven online surveys were prepared for each of the categories below and sent in March 2018.

Ref	Sent to	Number of responses
1	Heat pump suppliers and distributors	9
2	Heat pump installers	6
3a	Building industry professionals	19
3b	London Energy Transformation Initiative participants (LETI)	28
4	Mechanical and Electrical Engineers	10
5	Developers and housing associations	8
6	London boroughs - Energy and sustainability officers	8

**Table 5.01 – Surveys issued and number of respondents**

As stated in the *Acknowledgments* section we would like to reiterate our sincere thanks to the 81 people who have responded to these surveys. Although some of the surveys were short, most of the responses given were very detailed and the majority of respondents dedicated as much as 40 minutes to assist this study.

Nine suppliers and distributors have responded including Daikin, Mitsubishi, Kensa, Vaillant, Glen Dimplex, Star Renewable Energy, Stiebel Eltron, NIBE and Freedom Heat Pumps. The heat pump brands being installed by the installers also include Samsung, Viessmann, and Ochsner. The majority of other respondents were energy/sustainability consultants, Local Authority energy/sustainability officers, housing associations, developers, mechanical engineers and contractors.

For more statistical information about who completed the survey, please refer to Appendix J.

### 5.3.2 What are the key general messages coming out of the survey?

This section summarises briefly common themes emerging from the responses. Individual responses have also been provided to the GLA, along with a survey analysis tool enabling responses to be analysed by category. It should be noted that the responses do not only focus on heat pump systems in London.

#### General

When asked about the main challenges to a rapid increase in the uptake of heat pumps, the five key themes repeated across several responses were:

- The need for mechanical design of building services to evolve, particularly to enable lower supply temperatures;
- The higher capital costs of heat pumps;
- The additional training and skills required to deliver quality installations;
- Commissioning;
- Maintenance.

Three other important considerations were the electricity infrastructure (its ability to accept a significant increase in the number of heat pumps, interaction with the DNO), building regulations and planning policy (as it is perceived as a barrier to a wider uptake of heat pumps, particularly in London).

In terms of challenges which are specific to London, density (reduced footprint, reduced roof space) is quoted by many respondents.

#### Which proportion of your projects include a heat pump?

Compared to the statistics set out in the Heat Pump Market reports, the proportion of respondents that had installed heat pumps was not insignificant and suggests that they are a growing solution.

The majority of developers, housing associations and local authorities also expect the proportion of heat pumps to increase in the future.

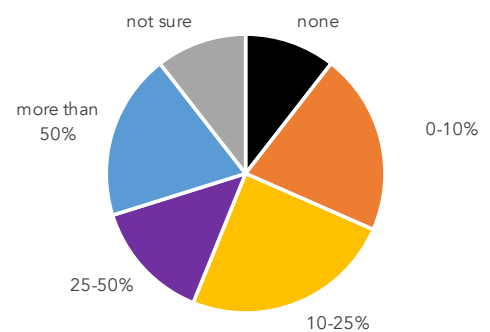

#### Key benefits of heat pumps

Although the opinions diverge on what the most important benefits of heat pumps are, on average the following ranking can be established from the respondents:

1. Lower carbon emissions
2. No combustion/local pollution
3. No gas connection
4. Lower running costs
5. Safety



**Key reasons why heat pumps are not specified more**

Again, the opinions diverge on what the key perceived issues are with heat pumps but, on average, the following ranking can be established from the respondents:

1. Lack of user/client awareness
2. Capital costs
3. Mechanical design / technical feasibility
4. Architectural integration / visual impact
5. Electricity grid limitations
6. Concerns over maintenance
7. Running costs
8. Noise

**Do you expect heat pumps to become the main solution for heating in the future?**

More than two thirds of the respondents (excluding heat pump suppliers and installers) seem to believe that heat pumps will become the main heating solution in the future, with some of them thinking that it will only happen in the longer term though.

Less than 10% of the respondents think that heat pumps will not become the main solution for heating while 28% are unsure.

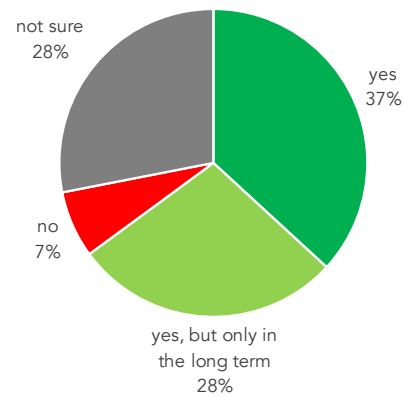

This is a very good indication that heat pumps are likely to play a growing role for the delivery of low carbon heat in London.

**Energy efficiency**

The lack of consensus over the best metric to be used to assess the actual energy efficiency of heat pumps is worrying with SCOP and SPF earning less than 35% of the votes and the rest of them scattered across other metrics including the SEER and the SAP default efficiency. More consensus and consistency is required.

**Hot water generation**

The survey revealed that most respondents are not considering gas generation of hot water in parallel with the heat pump on their projects (only 26%). More than 40% of them have hot water generated by the heat pump and 38% by the heat pump with electrical top-up. Only 2% have hot water generated by electricity only. These various system configurations will have an impact on efficiency and therefore on carbon emissions.

This is echoed by suppliers who indicate that hot water storage may not be incorporated in the same unit but generally forms part of the same system.

**Flow and return temperatures**

There was a reduced number of respondents in this category (10) with 50% of them indicating a flow temperature of 45°C on their systems. 20% of them indicated 55°C and the remaining 30% of them a lower or higher temperature.

A significant number of respondents highlighted the ‘business as usual’ mechanical design of heating system with a flow temperature of 80°C as a barrier to the uptake of heat pumps which needs addressing. Mechanical design must evolve towards lower flow and return temperatures.

**Impact on the electricity grid**

The opinions of mechanical and electrical engineers on the impact of heat pumps on the electricity grid were sought.

A quarter of respondents indicated that it led to significant additional cost. However, the other respondents did not highlight the cost impact as significant. A respondent also highlighted the savings associated with the omission of the gas infrastructure.

A few respondents highlighted that that it was dependent on the local electricity network and its potential need for reinforcement as new developments generally need a new substation anyway.

Some suggested that the additional impact of heat pumps has been somewhat offset by a reduction in other loads (e.g. lighting), while some highlighted the promises of smart grids, demand control and battery (or thermal storage) in the future which will help with heat pump integration. Please refer to section 6.0 for a summary on the potential impact on the electricity grid.

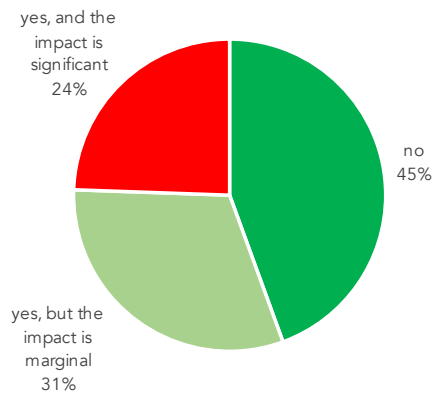

**5.3.3 Other comments**

This section goes beyond the ‘general findings’ of the previous section and focuses on survey outputs which are specific to each category of respondents.

All **suppliers** expect air-to-water heat pumps to be more in demand in the future. Specifically, monobloc units in residential developments and ground source systems in the commercial sector.

The consensus from clients (i.e. housing associations and developers) appears to be centred around uncertainty and the lack of confidence in heat pumps performance and products.

On the subject of RHI and its effect on heat pumps, opinions from suppliers were generally negative particularly for large scale developments. The structure of RHI does not consider factors such as up-front capital costs, therefore it does not provide incentives for developers who are typically not concerned with running costs. This has resulted in increased uptake of biomass and solar thermal over heat pumps across the UK. Suppliers also acknowledge the risk in the phasing out of RHI post 2020/21 and concern over the lack of a long-term mechanism to bring heat pumps to the mass market. Many emphasise the need for “carrot and stick” incentives over subsidy schemes.

*"It is clear that the electricity grid is decarbonising, which is not fairly represented in the current Building Regulations."*

*"It is likely that we will increase the number of heat pumps because of the change in policy. Heat pumps appear to be the most viable option for providing low carbon heat as CHP is becoming less viable. Although more work is needed to understand their performance, costs and reliability."*

*"Heat pumps are part of the future, but need to be considered on a building by building basis. Low temperature wet systems in buildings are technology agnostic and allow for the roll out of heat pumps or any other viable renewable heating technology."*

*"They are ultra reliable and ultra durable. Any issues elsewhere in the market have typically been linked to poor design."*

*"Design, design and design. We know how heat pump systems will work before they are installed."*

*"Once sub-station works are required an incremental uplift in capacity is proportionally cheap until you hit a local infrastructure cap, then the increase may be very expensive"*

## 5.4 Case studies

This section identifies some case studies of heat pump installations. The list has been prepared based on an initial research and discussions with suppliers and installers.

### 5.4.1 Residential heat pumps

#### **Parkside Place, Hammersmith**

Building scale:	40 apartments
Type:	New build
Heat pump type:	Individual exhaust air source heat pumps and air source heat pumps
Status:	In operation
Contact:	NIBE



Figure 5.01 – Photographs of Parkside Place (© Linden Homes)

The 23 single-level apartments were each equipped with the NIBE F470 exhaust air heat pump system. The 16 split-level duplexes and one mews house were each fitted with an air source heat pump package system made up of an 8kW NIBE F2040 air source heat pump and a NIBE VVM320 combined water storage and controls unit.

Type	Ref	Examples	Description
AIR SOURCE	Small-A2	Split systems	The heat pump is split into two units: an external one and an internal one. Refrigerant circulates between the two units.
	Small-A4	Exhaust air heat pump	The whole heat pump is located internally in a packaged unit. It combines an air source heat pump (using exhaust air) and mechanical ventilation system.

Table 5.02 – Types of heat pumps used at Parkside Place



Figure 5.02 – The exhaust air source pump (left) and air source heat pump package (right) (© Nibe)

**Wandsworth Riverside Quarter**

Building scale: 504 apartments  
 Type: New build  
 Heat pump type: 2.5 MW Aquifer Thermal Energy Storage (ATES) system using heat pumps  
 Status: In operation  
 Contact: Iftech



Figure 5.03 – Photographs of Wandsworth Riverside Quarter (© Frasers Property)

The heat pump system at Wandsworth Riverside Quarter is part of a communal heating system which also includes communal gas boilers and a gas CHP plant. It is a large Aquifer Thermal Energy Storage (ATES) system with a capacity of 2.5MW. There are eight 120m deep boreholes connecting the heat pumps to the aquifer.

Type	Ref	Examples	Description
WATER SOURCE	Medium-W1	Communal water source heat pump and Aquifer Thermal Energy Storage (ATES) system	Heat is generated by a communal open-loop water source heat pump (e.g. abstracting and rejecting water to the aquifer). A water-based system is used to distribute heat around the building / to each unit via a Heat Interface Unit (HIU).

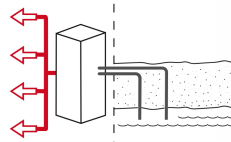

Table 5.03 – Type of heat pumps used at Wandsworth Riverside Quarter

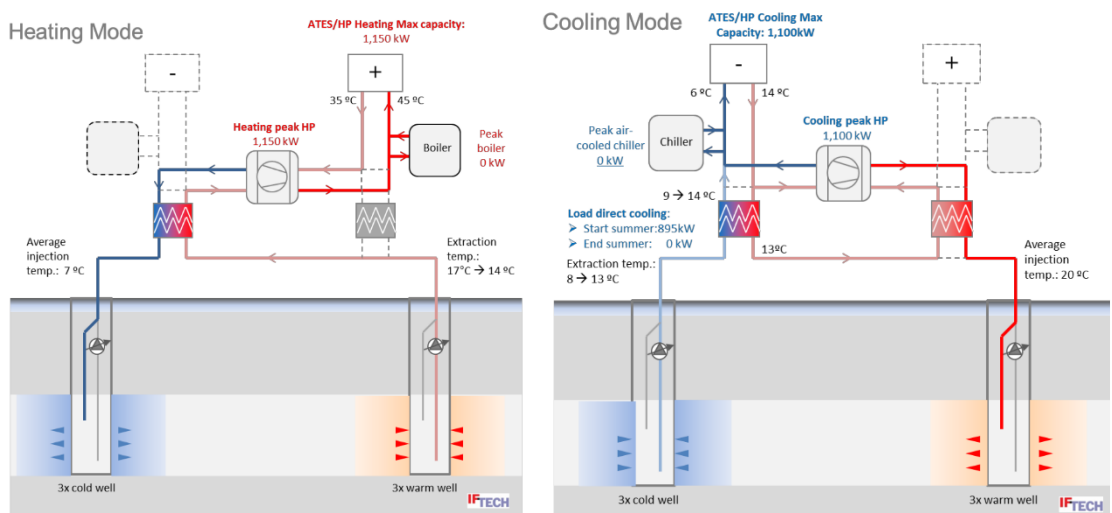

Figure 5.04 – Heating and cooling schematic for Riverside Quarter ATES heat pump system (© Iftech)

**8 tower blocks in Enfield**

Building scale: 400 units  
 Type: Refurbishment  
 Heat pump type: Ground source heat pump (unit in each dwelling)  
 Status: Construction  
 Contact: Kensa



Figure 5.05 – Photographs of two of the Enfield tower blocks retrofitted with the heat pump system and of the open space where the ground array is located (© Kensa)

Previously electrically heated, apartments in these eight tower blocks will now be heated by individual Kensa ‘Shoebox’ water-to-water heat pumps, each of them connected to a water loop. There are 16 underground loop, each with eight 200m deep boreholes.

Type	Ref	Examples	Description
GROUND SOURCE	Medium-G2 	Communal ground loop connected to individual heat pumps	A ground loop is supplying water to individual water-to-water heat pumps in each unit.

Table 5.04 – Type of heat pump used at Enfield



Figure 5.06 – Underground water loops (left) and individual ‘Shoebox’ heat pump (© Kensa)

**Inverness Street, Bayswater**

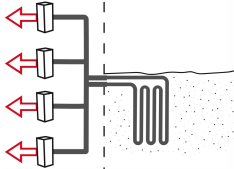
Building scale:	20 apartments
Type:	New build
Heat pump type:	Individual air source heat pumps (split systems)
Status:	In operation
Contact:	Daikin or Better Planet

**Kingston Heights**

Building scale:	137 apartments and 145-bedroom hotel
Type:	New build
Heat pump type:	2.3MW water source heat pumps coupled with heat pumps in each unit (41)
Status:	In operation
Contact:	Mitsubishi

**Wandsworth Riverlight**

Building scale:	706 apartments
Type:	New build
Heat pump type:	2.9 MW Aquifer Thermal Energy Storage (ATES) system using heat pumps, part of an Energy Centre also including gas boilers and gas CHP
Status:	In operation
Contact:	Iftech

**Meadow Flats, St Ives**

Building scale:	26 units
Type:	New build
Heat pump type:	Ground source heat pumps
Status:	In operation
Contact:	Dimplex

**5.4.2 Non-residential heat pumps****One New Change**

Building scale:	Large mixed use (retail and offices)
Type:	New build
Heat pump type:	Open-loop and closed loop heat pump system
Status:	In operation since 2011
Contact:	Hoare Lea

**50 Grosvenor Hill**

Building scale:	Medium-scale office building
Type:	New build
Heat pump type:	Ground source heat pump
Status:	In operation since 2012
Contact:	Grosvenor Estates

**300 Euston Road**

Building scale:	Large office building
Type:	Refurbishment
Heat pump type:	Air source heat pump
Status:	In operation
Contact:	British Land

5.4.3 District scale heat pumps

**Gorbals, Glasgow**

Scale: : District heating  
 Type: Refurbishment  
 Heat pump type: 2.5MW water source heat pump system  
 Status: Construction  
 Contact: Star Renewable Energy



Figure 5.07 – Photographs of the site near the River Clyde (© Star Renewable Energy)

The heat pump system at the Gorbals is part of a district heating system which also includes communal gas boilers for top up and back up. It is a large river source heat pump system with a capacity of 2.5MW. The project has received a 50% loan from the District Heating Loan Fund, with the rest of the project funded with a grant from the Low Carbon Infrastructure Investment Fund (LCIFP). It will be operated by an ESCO initially owned by Star Renewable Energy.

Type	Ref	Examples	Description
WATER SOURCE	Large-W1/2	Open-loop water source heat pump supplying heat to a District Heating network	The system will generate heat at a temperature of 80°C

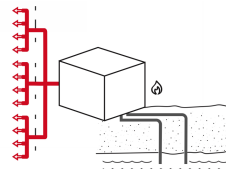

Table 5.05 – Type of heat pump used at the Gorbals

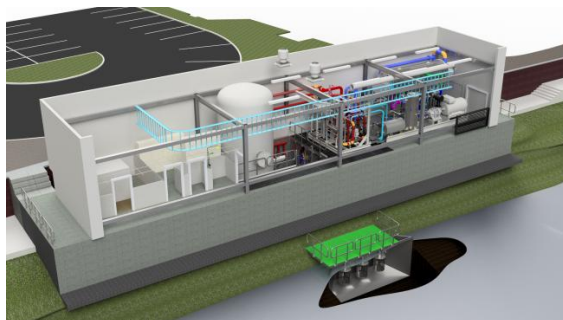

Figure 5.08 – Heat pump and plant next to the River Clyde (© Star Renewable Energy)



# 6.0

## IMPACT OF HEAT PUMP DEPLOYMENT

---

The use by the GLA of a lower carbon factor for electricity in place of the outdated factor used in Building Regulations calculations will significantly change the comparative carbon performance of heat pumps and gas-CHP, in favour of heat pumps.

Using eight case studies with different heat pump systems, our analysis demonstrates that heat pumps have the potential to comply with the draft London Plan (2017) and deliver significant carbon savings.

This section also includes a high level review of their impact in terms of capital cost, running cost and space requirements. It is very clear from these assessments that the conclusion depends on which type of heat pump system is being considered. Overall, capital costs and heating costs for the majority of heat pump systems are likely to be greater than conventional gas-based systems, although there is a significant degree of variability. Operational heating costs are lower than direct electric heating systems.

## 6.0 IMPACT OF HEAT PUMP DEPLOYMENT

The previous sections have established that heat pumps are expected to play an important role in the delivery of low carbon heat in London. This section provides an initial review of the implications they would have in terms of carbon savings, capital costs, running costs, space and noise when compared to a 'baseline' approach relying on a connection to a District Heating network with gas-fired boilers and CHP. Given the breadth of heat pump solutions available and the number of building types, this review was undertaken using three different methodologies:

- Energy and carbon savings were quantitatively assessed for 8 different building types. For clarity, only one heat pump system (relevant for each building type) was modelled;
- Capital costs, space requirements and noise were qualitatively assessed for all heat pump systems. For clarity, only a medium density apartment building was considered;
- Capital costs, running costs and space requirements were quantitatively assessed in more detail for a selection of heat pump systems in the medium density apartment building.

### 6.1 Energy and carbon

#### 6.1.1 Part L impact and actual carbon savings

One of the main drivers behind the potential large-scale deployment of heat pumps in London is the aim of reducing fossil fuel consumption and greenhouse gas emissions. In order to estimate the quantitative impact of heat pumps on energy demand and carbon savings, two energy demand scenarios have been assessed.

The first assessment uses energy demand data from **Part L modelling results**. This is to check the carbon savings impact of heat pumps against other technologies using the Part L / NCM calculation methodology required for demonstrating compliance with the London Plan and Building Regulations. The modelling has been done in accordance with the GLA guidance document for estimating Part L emissions, e.g. the Target Emission Rating is based on a gas boiler.

As the Part L / NCM methodology is a Building Regulation compliance tool and the results do not accurately represent actual energy usage in buildings, the second assessment uses benchmarked predicted energy consumption data in order to assess the impact of heat pumps against a more realistic energy demand. This is to estimate the potential **actual carbon reduction benefits** of heat pumps in operation.

#### 6.1.2 Case studies modelled

Several case studies of common development types in London were investigated. These include residential buildings, a large school building, office buildings and 'district combinations', i.e. a residential led group of 15 buildings and a mixed-use group of 15 buildings. The following case study development types have been modelled with the described heat pump systems. This is to assess a range of applications types and variations of heat pump designs. While many other system architectures are possible, it was considered that the above combinations would provide a representative indication of the impact of heat pumps on energy and carbon savings. This has allowed the energy saving and carbon reduction benefits of the technology to be assessed and compared for each case to a 'business as usual' scenario based on gas-fired CHP.

Case study	Modelled heat pump system
1. Residential Block: 70 units	Centralised air source heat pump with VRF distribution and secondary cascading heat pumps in each unit delivering space heating and hot water.
2. Residential Block: 100 units	Closed loop boreholes providing ground temperature water to be distributed to all units (at 10°C). Individual heat pumps in each dwelling providing space heating (at 35°C via underfloor heating) and hot water (at 65°C) with thermal storage.
3. Primary School (6,500m <sup>2</sup> )	Air source heat pump generating space heating (at 35°C via underfloor heating) and hot water (at 65°C) with thermal storage.
4. 100-bed Hotel (3,000m <sup>2</sup> )	Centralised air source heat pump VRF system providing space heating (and cooling) to all areas and AHU heating/cooling coils. Hot water generated by a dedicated air source heat pump.
5. Office Building (7,000m <sup>2</sup> )	Centralised air source heat pump with hot water loop (35°C - 40°C) providing space heating via fan coil units. Hot water generated using direct electric point-of-use heaters (toilets and kitchenettes only).
6. Office Building (50,000m <sup>2</sup> )	Ground source heat pump with hybrid electric heat recovery providing space heating via a hot water distribution loop (35°C - 40°C) and local fan coil unit terminals. Hot water generated using direct electric point-of-use heaters (toilets and kitchenettes only).
7. District (Residential)	Energy centre with closed-loop boreholes coupled to a 2-stage high temperature heat pump generating 70°C to 80°C to a thermal store. Hot water distribution to all units.
8. District (Mixed-use)	Energy centre with closed-loop boreholes couple to single stage heat pump generating 50°C to a thermal store. Space heating taken directly from local heat interface units. Hot water generated by local indoor water-to-water heat pump unit (40°C to 65°C increase) feeding off the primary loop.

Table 6.01 – Case studies and modelled systems

### 6.1.3 Important notes

**Carbon factor for electricity.** A grid electricity carbon emissions factor of 302 gCO<sub>2</sub>/kWh has been used for all calculations in place of the outdated figure that is currently used in Part L (i.e. 519 gCO<sub>2</sub>/kWh). 302 gCO<sub>2</sub>/kWh is the figure used in other evidence bases prepared for the GLA by Buro Happold and AECOM. It is high compared with other current and predicted estimates (e.g. 233 gCO<sub>2</sub>/kWh proposed for SAP 10). The findings of this analysis will therefore be conservative and not biased towards heat pumps.

**Energy efficiency.** The energy demand assessments for the case study buildings have been developed to conform to the requirements of the Draft London Plan (2018) where possible<sup>1</sup> (i.e. all residential developments must be at least 10% better and non-residential developments at least 15% better than Part L 2013 through energy efficiency only).

<sup>1</sup> It should be noted that for the hotel case study there was no reasonable energy efficient 'Be Lean' specification that enabled the model to achieve 15% carbon savings over Part L. This is due to the way that Part L and the NCM (National Calculation Methodology) overestimates hot water usage in hotels, representing over 80% of the building's total energy demand in this case. Because the boiler efficiency in the 'Be Lean' case is limited to 91% (as set out in the GLA's Guidance on Preparing Energy Assessment) there is very limited scope to achieve significant further carbon savings in other areas. A 5% Part L improvement for the hotel's 'Be Lean' case has therefore been taken for these calculations.

#### 6.1.4 Calculated heat source carbon factors

The table on the following page (Table 6.03) provides a summary of the heat source carbon emission factors that have been calculated for each case study. These figures are based on delivered heat and therefore include heat distribution and storage losses.

They have all been calculated based on the key assumptions summarised below which are based on Etude's project experience. Heat carbon factors for space heating and hot water have been calculated separately as the system used and/or the generation efficiencies were not the same for both. Carbon factors were then applied separately to each.

**Communal heating using gas boilers** provide a reference scenario based on boilers operating at 91% efficiency with 10% distribution losses within the building. An additional 20% loss is assumed for the district heating based communal boiler systems, which increases the carbon factor of heat from 264 to 330 gCO<sub>2</sub>/kWh.

**Communal heating using gas-CHP** provides the baseline scenario, which clearly highlights the erosion of carbon benefits previously associated with gas-fired CHP as a result of the reduced electricity carbon emissions factor. The carbon content of heat for this system is higher than equivalent systems using heat provided completely by gas boilers. It is assumed the CHP system operates with a thermal efficiency of 48% and an electrical efficiency of 32%.

**Heat pump systems** provide the lowest carbon heat for all case studies, though significant differences exist between the various types of heat pump. The lowest carbon heat is achieved by the residential block using ground source heat pumps coupled to a communal ground loop. This system benefits from very small distribution losses due to the ambient flow temperature and relatively high efficiencies of 380% for space heating at 35°C and 290% for DHW at 60°C offered by ground source heat pumps.

The **district heat based systems** generally have higher carbon heat as a result of reduced efficiencies from the higher flow temperatures assumed for this system, and additional distribution losses. This is despite assuming the use of a specialist two-stage heat pumps that can achieve relatively high efficiencies of 250-290% even at flow temperatures that would be considered high for a normal heat pump. Water heating in the residential block is associated with the highest carbon heat for the heat pumps assessed due to the low efficiency of 170% that is assumed for an air source unit heating water to 65°C.

**Direct electric systems** provide the highest carbon heat with the exception of the two district heating systems when heat is provided by either gas boilers or gas CHP.

	Communal heating with gas boilers (gCO <sub>2</sub> /kWh)	Communal heating gas CHP-led (gCO <sub>2</sub> /kWh)	Heat pump system (gCO <sub>2</sub> /kWh)		Direct electric Resistance (gCO <sub>2</sub> /kWh)
			Space Heating	Hot Water	
1. Residential Block: 70 units	264	274	101	178	302
2. Residential Block: 100 units	264	274	78	106	302
3. Primary School (6,500m <sup>2</sup> )	264	274	89	181	302
4. 100-bed Hotel	264	274	101	180	302
5. Office Building (7,000m <sup>2</sup> )	264	274	101	302	302
6. Office Building (50,000m <sup>2</sup> )	264	274	83	302	
7. District (Residential)	330	342	148	148	
8. District (Mixed-use)	330	342	141	120	

Table 6.02 – Modelled heat source carbon emission factors – based on 302 gCO<sub>2</sub>/kWh for electricity

#### Notes concerning values in Table 6.02

- The 'CHP' case assumes an 80% thermal load from CHP and 20% from gas boilers. This represents a very high proportion and was used to clearly show the impact of the CHP rather than 'blending' it with the effect of a gas boiler. CHP total efficiency of 80% with heat-to-power ratio of 1.5 are assumed.
- For 'Gas Boiler' and 'CHP' cases 1 to 6, internal pipework heat distribution losses of 10% are assumed. Cases 7 and 8 factor in an additional 20% losses through the underground district heat network pipes.

#### 6.1.5 Part L assessments

The above carbon contents of heat have been applied to the Part L results to assess which combination of case studies/heating systems were likely to be able to achieve a 35% improvement over Part L 2013, taking into account the reduced emissions factor for grid electricity.

The table and bar chart on the following page (Table 6.03 and Figure 6.01) indicate that the modelled heat pump systems were generally lower carbon than the alternatives and provided a larger percentage reduction over the Part L baseline, in line with the requirements of the draft London Plan (2018) requirements. Please note that none of the case studies above include PVs, which would enable some scenarios to achieve additional carbon savings and potentially comply with the 35% carbon reduction improvement over Part L 2013.

*\* For the purposes of this calculation the future Part L TER (Target Emission Rate) has been adjusted proportionately to difference in BER calculated using Part L 2013 emission factors for grid electricity and the figure of 302 gCO<sub>2</sub>/kWh assumed in this study.*

**Estimated percentage improvement over Part L (%) assuming a 'London Plan TER with gas boilers**

	Communal heating with gas boilers	Communal heating gas CHP-led	Heat pump system	Direct electric Resistance
1. Residential Block: 70 units	10%	7%	44%	-1%
2. Residential Block: 100 units	10%	7%	57%	-1%
3. Primary School (6,500m <sup>2</sup> )	11%	10%	24%	6%
4. 100-bed Hotel	-9%	-13%	21%	-22%
5. Office Building (7,000m <sup>2</sup> )	26%	25%	27%	21%
6. Office Building (50,000m <sup>2</sup> )	19%	19%	20%	
7. District (Residential)	-9%	-12%	42%	
8. District (Mixed-use)	4%	2%	44%	

Table 6.03 – Comparison of Part L improvement for each case study and heating system type

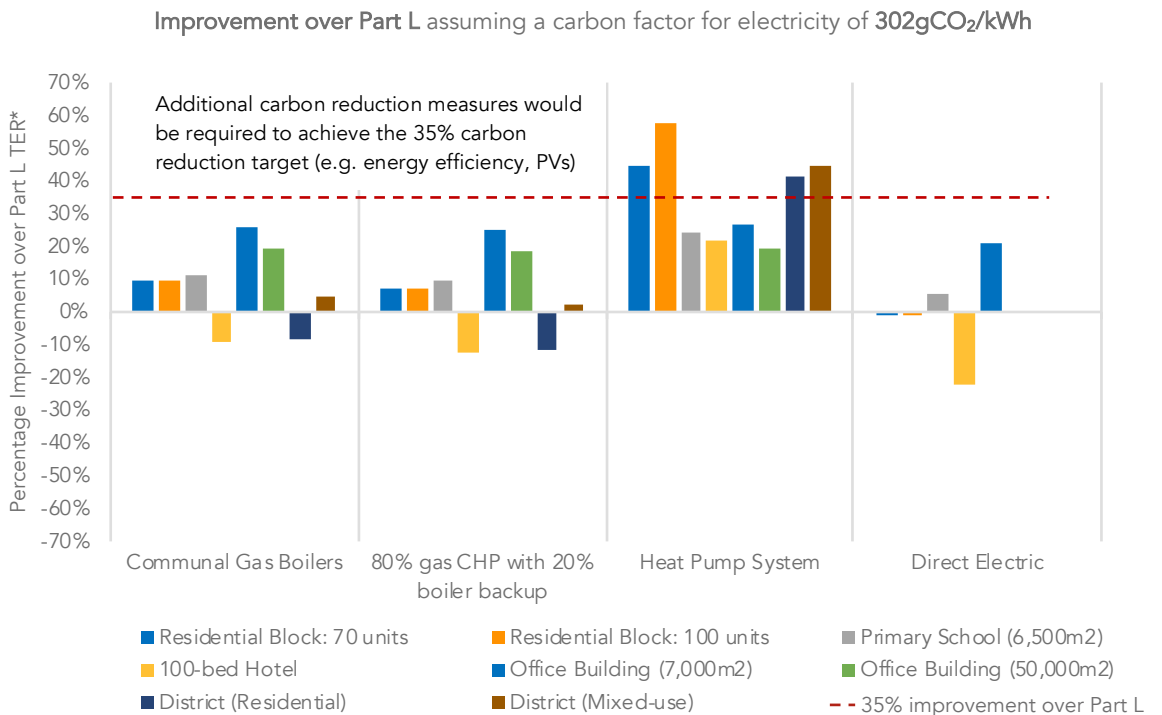
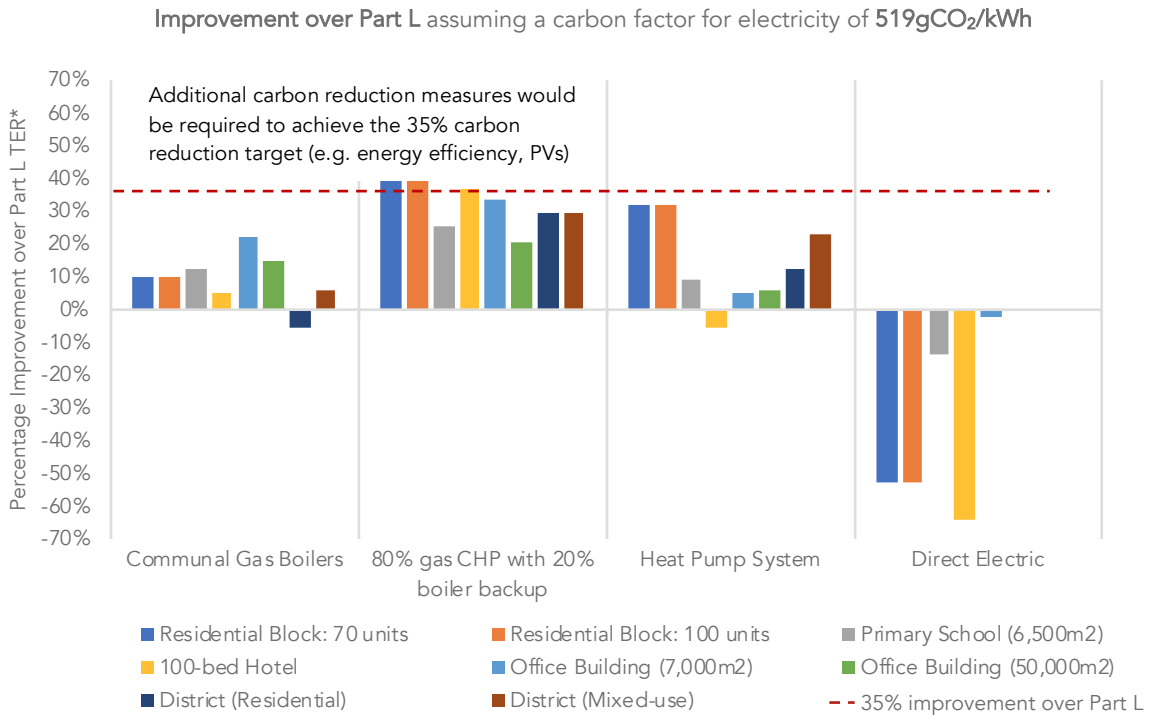

Figure 6.01 - Comparison of Part L improvement results (assuming a carbon factor of 302gCO<sub>2</sub> /kWh for electricity)

The results shown above demonstrate that heat pump systems are able to provide substantial Part L improvements when compared to the other technologies. This is due to a combination of the efficiency heat pumps can achieve, decarbonisation of grid electricity and lower distribution losses. As a result of grid decarbonisation, gas-fired CHP now performs worse than gas boilers as the electricity

generated no longer provides sufficient carbon offsetting to overcome the inefficiencies of CHP heat generation. The difference can be seen clearly on the two figures below, which are based on a carbon factor of electricity of 519gCO<sub>2</sub>/kWh (SAP 2012) and 233 gCO<sub>2</sub>/kWh (SAP 10).

For comparison, the graph below indicates what the current Part L performance of these systems would be, using a carbon factor for electricity of 519gCO<sub>2</sub>/kWh.



**Figure 6.02 - Comparison of Part L improvement results (assuming a carbon factor of 519gCO<sub>2</sub> /kWh for electricity)**

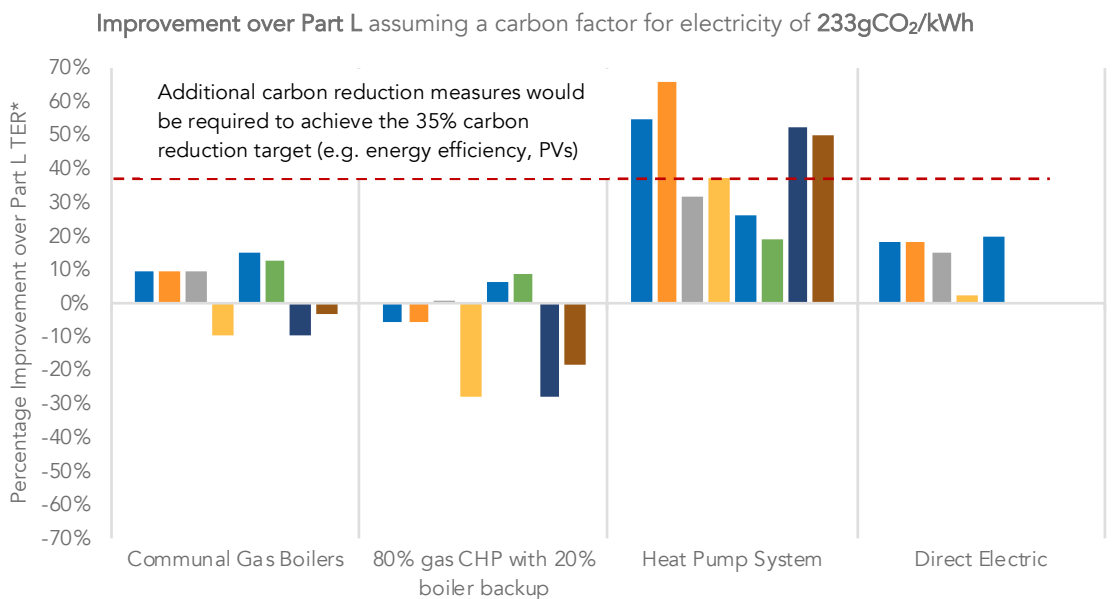

**Figure 6.03 - Comparison of Part L improvement results (assuming a carbon factor of 233gCO<sub>2</sub> /kWh for electricity) (same legend as Figure 6.02 above)**

### 6.1.6 Actual carbon savings (based on energy benchmarks)

As it is recognised that Part L is primarily a Building Regulations compliance tool and is not meant to predict actual energy consumption or carbon emissions, a second energy assessment based on benchmark energy data has also been undertaken. This is more likely to reflect actual carbon emissions.

For example, Part L underestimates heating demand in a school. If carbon emissions are only extrapolated from the Part L assessment, it would underestimate the differences between systems.

The benchmark data has been taken from CIBSE Guide F for the commercial buildings and from PHPP modelling for the residential buildings<sup>13</sup>. Both sets of data include both regulated and unregulated energy consumption. They are summarised below.

These have been adapted from the original sources to reflect energy demand rather than consumption (i.e. excluding boiler efficiencies, distribution losses, etc.). Benchmark data from CIBSE Guide F has also been reduced by 25%<sup>14</sup> to account for recent improvements in the energy performance of new buildings.

	Benchmark Source / CIBSE Guide F Reference	Space Heating Demand (kWh/m <sup>2</sup> )	Hot Water Demand (kWh/m <sup>2</sup> )	Electricity Demand (kWh/m <sup>2</sup> )
<b>Residential</b>	PHPP Modelling	30	30	40
<b>Primary school</b>	Education, Primary (good practice)	50	10	40
<b>Hotel</b>	Hotels, Holiday (good practice)	90	15	20
<b>Office</b>	Type 4 Office (good practice)	80	10	100

**Table 6.04 – Benchmark data used for energy assessment**

<sup>13</sup> PHPP is a modelling tool which is more accurate at predicting future energy use. Given the lack of published information on the actual energy use in apartment blocks, this was considered a reasonable approach.

<sup>14</sup> Based on Etude's project experience.



	Communal heating with gas boilers (kgCO <sub>2</sub> /yr)	Communal heating gas CHP-led (kgCO <sub>2</sub> /yr)	Heat pump System (kgCO <sub>2</sub> /yr)	Direct electric Resistance (kgCO <sub>2</sub> /yr)
1. 70-unit residential block	164,000	168,000	137,000	178,000
2. 100-unit high rise residential block	235,000	240,000	190,000	254,000
3. 6,500 sqm primary school	212,000	219,000	200,000	238,000
4. 100-bedroom hotel	293,000	300,000	251,000	320,000
5. 7,000 sqm office	369,000	375,000	364,000	393,000
6. 50,000 sqm office	3,958,000	4,007,000	3,913,000	
7. District (Residential)	4,274,000	4,373,000	3,619,000	
8. District (Mixed-use)	3,648,000	3,724,000	3,388,000	

Table 6.05 – Results of predicted actual carbon saving assessment - Total annual carbon emissions

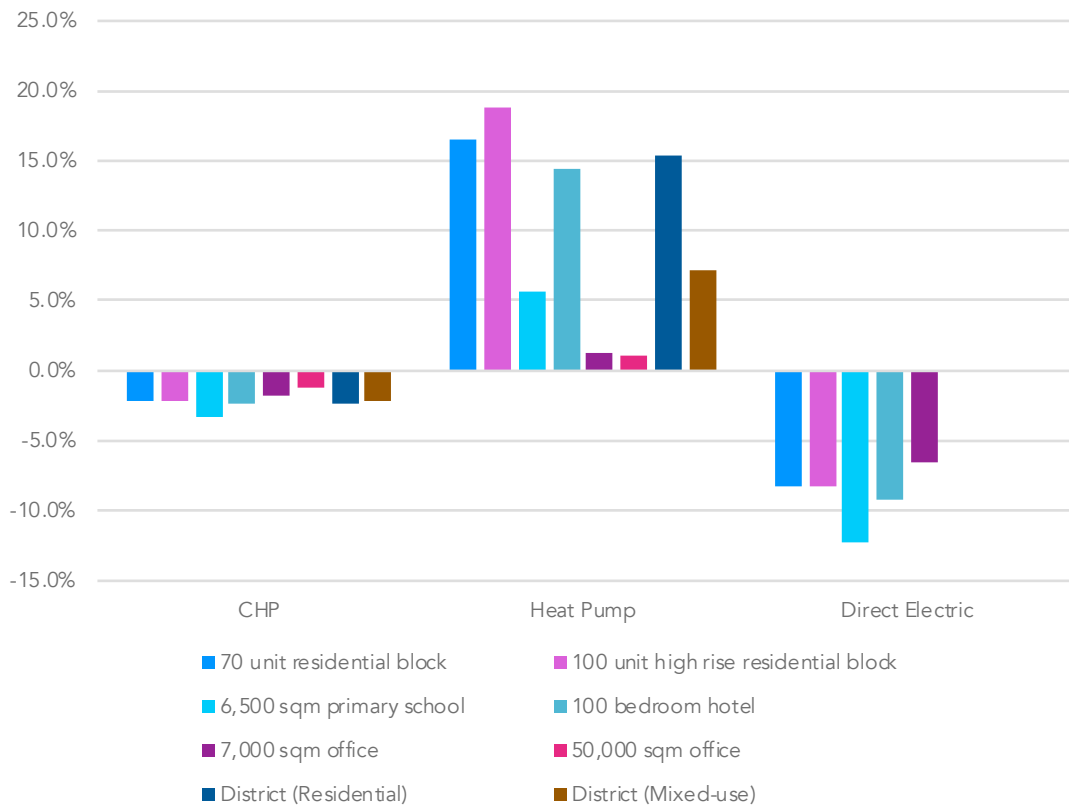

Figure 6.04 – Summary of estimated carbon emission savings compared to a gas boiler scenario

As can be seen from the above results, in each of the cases the heat pump system scenario achieves greater carbon savings compared to the gas boiler scenario. CHP and direct electric were found to be consistently worse performing in terms of carbon emissions than gas boilers across the board (assuming a carbon factor for electricity of 302 gCO<sub>2</sub>/kWh).

Heat pumps are able to provide the greatest energy efficiency and carbon saving benefits **when the overall heating / hot water system is designed around the characteristics of heat pumps**. For example, it is not ideal to centrally install a large heat pump system and distribute high temperature water throughout a building or district network, as may be the case for a conventional gas boiler or CHP installation. This is because heat pumps operate least efficiently at high output temperatures, there is generally little or no efficiency advantage of using large capacity heat pumps compared to small capacity heat pumps and pipework heat distribution losses are high when distributing water at a high temperature.

For the same reasons, heat pumps can be very efficient when connected to a low carbon heat source (e.g. waste heat) and supplying a 4<sup>th</sup> generation district heating system at ultra-low temperatures.

### 6.1.7 Looking ahead: net zero carbon buildings in operation in 2030

A high-level analysis was undertaken in order to investigate the future role of heat pumps in achieving net zero carbon buildings in operation in 2030.

The National Grid has recently published its updated Future Energy Scenarios (FES)<sup>15</sup>, which included projections for the electricity carbon factor in 2030. These four scenarios (i.e. steady progression, consumer evolution, two degrees and community renewables) are based on various parameters and two main axes: speed of decarbonisation and level of decentralisation. As it can be seen from the table below extracted from the latest FES report dated July 2018, the projected annual average carbon content of electricity varies between 48gCO<sub>2</sub>/kWh and 146gCO<sub>2</sub>/kWh. For the purpose of this high-level analysis, a figure of **100gCO<sub>2</sub>/kWh** has been assumed for electricity.

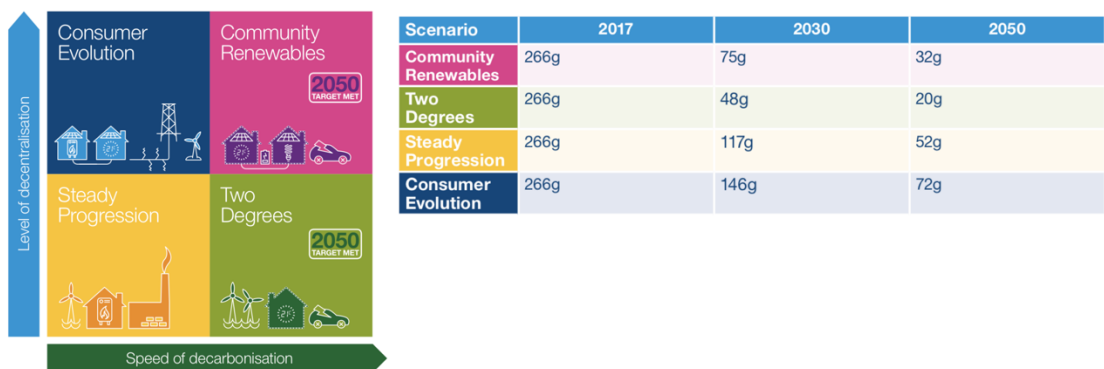

Figure 6.05 – Future electricity grid energy scenarios and projected annual average carbon content of grid-supplied electricity (© National Grid)

<sup>15</sup> Future Energy Scenarios, System Operator, National Grid, July 2018

Using the example of a medium density apartment building, the figure below demonstrates that very low levels of total on-site carbon emissions (i.e. approximately 2kgCO<sub>2</sub>/m<sup>2</sup>/yr), close to net zero carbon, can be delivered, if:

- Very high standards of energy efficiency are achieved;
- Roof-mounted PVs are maximised;
- An efficient heat pump system is provided.

The role of each component is very clear: energy efficiency reduces demand to the lowest level, heat pumps deliver low carbon heat and PVs play a significant role in offsetting on-site the residual carbon emissions.

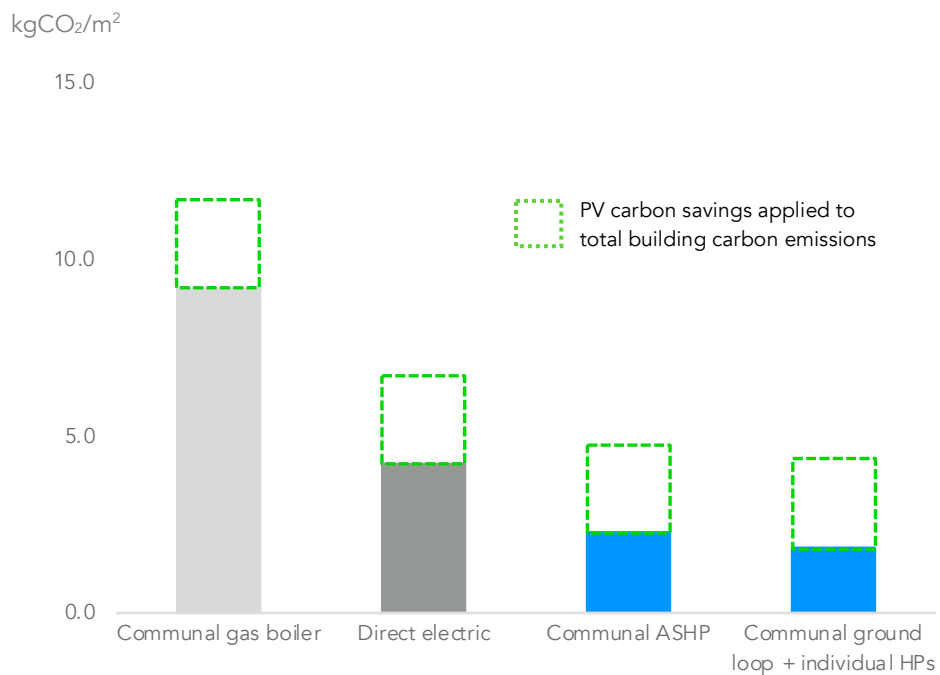

Figure 6.06 – Estimated total CO<sub>2</sub> emissions in 2030 (kgCO<sub>2</sub>/m<sup>2</sup> NIA) – high standard of energy efficiency

## 6.2 Impact on the electricity grid

The impact of heat pumps on the electricity grid is sometimes quoted as one of the barriers to a greater uptake of heat pumps in London. At the transmission level, National Grid has modelled scenarios of heat pump deployment ranging from 2 million up to around 20 million units being deployed by 2050<sup>16</sup>. While the use of heat pumps increases demand for electricity for heating, overall demand for electricity in the most ambitious heat pump deployment scenario actually decreases as a result of improved energy efficiency in other sectors and extensive use of energy storage technologies, driven by time of use tariffs.

<sup>16</sup> Future Energy Scenarios 2018

At the distribution system level, a range of studies have been carried out to investigate the potential impact of heat pumps and electric vehicles<sup>17</sup>. These studies generally conclude there will be impacts on both **capacity** and **power quality**, and that upgrades will be required. The impact on capacity depends on the market penetration of heat pumps, while the impact on power quality would be the result of clustering: a high number of heat pumps in a given location. Generally, the conclusions of individual studies should be treated with caution, as they can be quite sensitive to assumptions that may require further validation and research<sup>18</sup>. These reports indicate that there are four approaches to mitigate the impact of heat pumps on the electricity grid that the GLA should be aware of:

### **Building fabric energy efficiency**

Building fabric energy efficiency is a robust strategy to reduce peak demand on the electricity grid caused by heat pumps. Additional benefits include reductions in overall levels of energy consumption as well as operational cost and carbon emissions, regardless of the heating system. Modest levels of building fabric energy efficiency should be considered a pre-requisite for the efficient deployment of heat pumps (as this allows lower flow temperatures), while higher levels of building fabric efficiency (e.g. Passivhaus) could substantially reduce peak demand for electricity.

### **Demand side management**

Studies based on relatively inefficient traditional buildings accurately conclude there is little potential for demand side management of heat pumps, as the rates of heat loss are so high that it is not possible to effectively reduce the power consumption of heat pumps during periods of peak demand without an impact on the comfort of occupants. This need not be the case for new buildings, where significantly reduced rates of heat loss could enable demand side management of heat pumps, even during very cold periods.

A recent study<sup>19</sup> modelled Passivhaus buildings and demonstrated that preheating by an additional 2°C<sup>20</sup> stored enough thermal energy for the building could maintain a comfortable indoor temperature for up to five days during one of the coldest weeks of the year, without further energy input from the heating system.

### **Low carbon gas and hybrid heat pumps**

At least one study<sup>21</sup> identified low carbon or 'green' gas as a possible candidate for use in hybrid heat pump systems. These systems use a gas boiler instead of a heat pump to provide domestic hot water and space heating during peaks in winter demand, to reduce load on the electricity network. Control systems adjust the proportion of heat from the gas boiler and the heat pump based on cost or

---

<sup>17</sup> These include studies by Delta-EE, various Network Innovation Allowance projects and the Low Carbon London series of reports produced by UK Power Networks.

<sup>18</sup> For example, the operational profile of heat pumps is a key assumption. Some reports assume a profile based on combustion based heating systems, which is unlikely to be the case for heat pumps and may result in overestimating future peak demands.

<sup>19</sup> Renewable heating supply in Passive Houses on the smart grid, Prof. Richard Hofer, Hochschule Biberach, Germany (2017)

<sup>20</sup> Preheating was carried out during windy periods preceding relatively still cold weather, therefore the building's thermal mass was effectively used to store low carbon heat produced by a heat pump powered by low emission wind energy. The buildings investigated had a relatively high thermal mass that would be representative of an externally insulated concrete structure.

<sup>21</sup> Freedom Project Interim Report, Wales & West Utilities (2018)

emissions priorities. While this study concluded that these systems could provide cheaper heat, it did not appear to include all costs of heating, such as standing charges for gas supplies and additional maintenance/servicing for the gas boiler. A further consideration is that whilst heat from boilers burning fossil-based gas supplies may be cost competitive with heat from heat pumps, some studies<sup>22</sup> have indicated that green gas is likely to cost several times more than fossil-based gas, which could adversely impact the financial case for heating with green gas versus heat pumps.

It is also important to note that hybrid heat pumps do not provide a route to long term decarbonisation of heat unless low or zero emission gas is used for the lifetime of the system. Some studies<sup>23</sup> into the potential for green gas in the UK appear to include gas produced from refuse derived fuel (RDF), which is unlikely to be zero or low carbon. No studies reviewed as part of this work appeared to show clear calculations or evidence as to the actual carbon content of green gas. The impact on air quality also needs to be considered.

### Hydrogen

An alternative to using low carbon gas (and therefore to reduce load on the electricity network) is to burn hydrogen, which produces no carbon emissions at the point of combustion. There are, however, several limitations to this approach including the fact that conventional boilers could only burn a blend of around 20% hydrogen and 80% methane, therefore not offering a simple pathway to decarbonise heat (burning 100% hydrogen would require new boilers to be installed simultaneously across all parts of the network that were switching to supply pure hydrogen). Trials underway in the UK currently use hydrogen produced by steam reformation, which produces carbon emissions. The carbon neutrality of hydrogen currently relies on carbon capture and storage, which is yet to be demonstrated at scale in the UK. Production of low emission hydrogen is possible via electrolysis powered by renewable electricity, however the overall efficiency of heating would be less than 70% before accounting for distribution losses, compared to 260-300% for a typical heat pump. For this to be cost effective, it would be necessary for the electricity used for the electrolysis process to be purchased at very low prices to account for the reduction in efficiency.

### Mitigating the impact on the electricity grid - conclusion

The most robust route to decarbonise heating while mitigating impacts on the electricity grid for new developments is likely to be through excellent levels of building fabric efficiency combined with moderate thermal mass and smart heating controls. This approach could minimise heat demand during cold periods and allow pre-heating to 'ride-through' cold periods with reduced power draw from the electricity grid. Hybrid heat pumps using green gas could play a useful role for less efficient existing buildings that are more difficult to retrofit, though the carbon content of this gas should be clearly established. Finally, hydrogen produced via electrolysis powered by surplus renewable electricity may offer another combustion-based alternative to heat pumps, though low system wide efficiencies may mean heat pumps combined with battery storage are more cost competitive.

In any case, UKPN has indicated that they will actively plan for additional demand due to heat pumps, provided they have early visibility of any deployment plans, and are notified of installations on their networks.

---

<sup>22</sup> Biogas: A significant contribution to decarbonising gas markets? Oxford Institute for Energy Studies (2017)

<sup>23</sup> Review of Bioenergy Potential, Anthesis for Cadent Gas Ltd (2017)

### 6.3 Impact on capital costs

Assessing the impact of heat pumps on capital costs for new developments is challenging: firstly due to the variety of new building types and scales in London, but most importantly due to the variety of heat pump systems which can be applied to each building type and to the wide range of costs of these systems. This is reflected in the results of the surveys undertaken as part of this study: views on the capital costs of heat pump systems compared to a 'business as usual' London Plan compliant baseline varied substantially.

Heat pump systems are already widely used in a variety of commercial buildings (e.g. offices, retail, hotels). Individual heat pump systems are also often used for individual houses. This can be considered as evidence that their cost does not have a significant impact on viability for these types of development.

A similar justification cannot be used for medium to large scale residential buildings as there are only a few operational heat pump systems in London. This section therefore considers the potential additional costs for the developer of a medium density residential building of circa 85 units. A qualitative assessment of a large number of systems on capital costs has been considered and a quantitative assessment of a smaller number of systems has been undertaken. It compares the Mechanical and Electrical capital costs of heat pump systems against a baseline relying on a connection to a District Heating system with gas-fired CHP to assess the impact of the change in terms of:

#### 1. Infrastructure

The baseline capital costs include the district heating pipes to the edge of the site. It is assumed that all other district heating costs (e.g. energy centre) are not paid for by the developer. This approach has been adopted as is the case for the majority of new buildings in London.

#### 2. Building

The baseline capital costs include the costs of the heat substation on the ground floor and the heating distribution to each unit.

#### 3. Dwelling

The baseline capital costs include the costs of the heat interface unit in each apartment and of the heating emitters (e.g. radiators).

The key cost categories which have been considered are illustrated below.

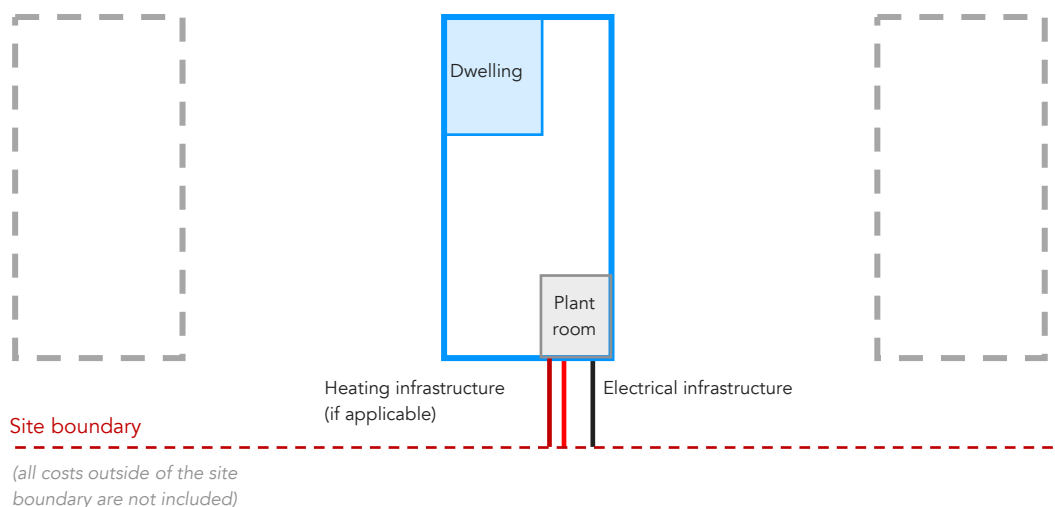
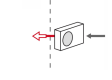
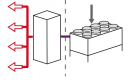
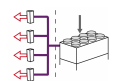
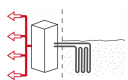
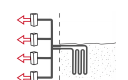
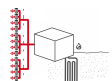
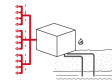

Figure 6.07 – Types of capital costs for the developer considered in this study

As an example, for a communal ground loop connected to individual heat pumps (Ground source Medium G-2), the ground loop would introduce significant additional '*infrastructure costs*' but also savings in terms of '*building costs*' as no central plant room would be required. However, it would also lead to additional '*dwelling costs*' due to the replacement of the heat interface unit with the individual water-to-water heat pump and its hot water cylinder. Another example would be a 4th generation District Heating network with air source heat pumps and a communal heat pump in each building connected to heat interface units. '*Infrastructure costs*' would be similar for the developer (i.e. DH pipes to the edge of the site). '*Building costs*' would be slightly higher due to the replacement of the heat substation by a building scale water-to-water heat pumps. '*Dwelling costs*' would be equivalent.

The scale of additional costs is indicated by 1 to 5 '+'. The scale of savings by 1 to 5 '-'. It indicates that costs comparisons are very dependent on the heat pump system. Please refer to Table 6.06 on the following page. Generally, individual heat pump systems are likely to be more expensive than communal systems as they add a significant cost at the dwelling level.

**Please note that this review does not include the impact of the RHI.**

Type	Ref	Example	Capital cost implications for developer		
			Infrastructure	Building	Dwelling
AIR SOURCE Small-A1		Monobloc	--	---	++++
AIR SOURCE Small-A3		Hybrid	-	---	+++++
AIR SOURCE Small-A4		Compact unit Heat Pump + MVHR	--	---	+++++
AIR SOURCE Medium-A1		Communal air source heat pump to heat interface units (HIUs)	--	++	=
AIR SOURCE Medium-A2		Communal air source heat pump to heat pumps	--	+	+++
AIR SOURCE Medium-A3		Communal VRF system air source heat pump to individual heat pumps	--	+	++
GROUND SOURCE Medium-G1		Communal closed-loop ground source heat pump to heat interface units (HIUs)	++	+	=
GROUND SOURCE Medium-G2		Communal ground loop connected to individual heat pumps	++	-	++
WATER SOURCE Medium-W1		Communal water source heat pump to heat interface units (HIUs)	+	++	=
AIR SOURCE Large-A1		DH network with primary air source heat pumps	=	=	=
AIR SOURCE Large-A2		4 <sup>th</sup> generation DH network with air source heat pumps and heat pump in each building	=	+	=
GROUND SOURCE Large-G1/2		4 <sup>th</sup> generation DH network with ground source heat pumps and heat pump in each building	=	+	=
WATER SOURCE Large-W1/2		DH network with primary water source heat pumps	=	=	=

**Table 6.06 – Qualitative appraisal of additional costs and cost savings for the developer of a medium density apartment block**

Please note that the above analysis includes only the majority of system types



In summary, for the small systems there is clearly an additional cost at the dwelling level. For the large scale systems, costs are comparable except there is a low additional cost at the building level for two of the heat pump scenarios (Large A2, Large G1/2). For the medium systems, there is a range of a scale of additional costs between the three levels (infrastructure, building, dwelling).

A more detailed analysis was also undertaken for four types of heat pump systems.

Scenario	Description		Description	
HP 1	Building level air source heat pump system with water distribution to HIUs		Communal air source heat pump to heat interface units (HIUs)	Heat is generated by a medium-scale / communal air source heat pump. A water-based system is used to distribute heat to each unit via a Heat Interface Unit (HIU).
HP 2	Building level air source heat pump system with refrigerant distribution to FCUs and separate system for DHW		Communal air source heat pump to heat pumps (e.g. VRF)	A refrigerant-based system is used to distribute heat to each unit where secondary heat pumps extract heat from it.
HP 3	Communal ground loop with individual heat pumps		Communal ground loop connected to individual heat pumps	A ground loop is supplying water to individual water-to-water heat pumps in each unit.
HP 4	Connection to Waste Heat Network with building level heat pump system		4 <sup>th</sup> generation DH network waste source heat pump and secondary heat pumps in each building	Heat is generated by a large-scale waste source heat pump system potentially used in conjunction with other systems (e.g. central gas boilers). Low temperature heat is distributed to secondary heat pumps in the building.

Table 6.07 – Overview of heat pump systems considered

Please refer to Appendix J for the summary of assumptions underlying this assessment.

The analysis summarised in the table on the following page indicates that the heat pump solutions are likely to cost between 0.4% and 2.9% more than the baseline. Although additional costs would vary substantially depending on the building and context, they are likely to be comprised in the range £930/unit (HP1)-£7,080/unit (HP3). HP1 represents the most common and economic solution, albeit not the most efficient.

This excludes any potential costs associated with electrical infrastructure costs as this it depends on the local context (e.g. requirement for a network upgrade or not) and the scale of the additional requirement (e.g. whether it triggers the requirement for a much larger substation).

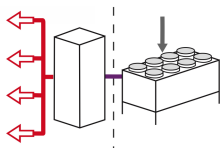
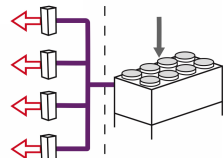
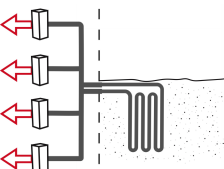
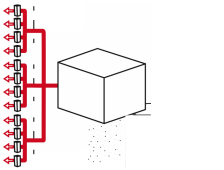
Scenario	Description	Additional costs (£)	Additional costs (£/m <sup>2</sup> GIFA)	Additional costs (£)	Additional costs (Proportion of total construction costs)
Baseline	Connection to District Heating Network with CHP	Ref	Ref	Ref	Ref
Ref 1	Communal gas boilers	- £50,000	- £7/m <sup>2</sup>	- £590/unit	- 0.2%
Ref 2	Direct electric heating	- £582,000	- £79/m <sup>2</sup>	- £6,850/unit	- 2.8%
HP 1	Building level air source heat pump system with water distribution to HIUs	+ £79,000	+ £11/m <sup>2</sup>	+ £930/unit	+ 0.4%
HP 2	Building level air source heat pump system with refrigerant distribution to FCUs and separate system for DHW	+ £203,000	+ £27/m <sup>2</sup>	+ £2,380/unit	+ 1.0%
HP 3	Communal ground loop with individual heat pumps	+£602,000	+£82/m <sup>2</sup>	+£7,080/unit	+ 2.9%
HP 4	Connection to Waste Heat Network with building level heat pump system	+£432,000	+£59/m <sup>2</sup>	+£5,080/unit	+ 2.1%

Table 6.08 – Overview of key impact on capital costs for the developer

It is however important to note that these cost estimates are in the higher ranges. The costs of HP3 could be significantly reduced with scale and if design and procurement are optimised (as it is the case for the eight tower blocks in Enfield – please refer to associated case studies). Costs of heat pumps are also generally expected to reduce over time as demand increases and the supply chain develops.

#### Future evolution of heat pump costs

The Department of Energy and Climate Change (DECC – now BEIS) commissioned Delta EE to undertake research into the potential cost reductions for air source heat pumps and ground source heat pumps between the market as it was in 2014 and a mass market scenario. These reports were published in 2016. The reports concluded that costs could reduce by 15-20%. This would be comprised of a 30-50% potential cost reduction in non-equipment costs and a 5-10% cost reduction in equipment costs. The cost reductions would be due to the larger installer base with larger companies, a consolidated supply chain, better sales channels and cheaper installation costs. The cost reduction associated with the equipment itself would be smaller as heat pumps can already be considered a mature technology at the European level.

## 6.4 Impact on running costs

It is important that the transition to low carbon heat does not lead to heating bills which are not affordable, particularly for those on low incomes. This is important as a move from gas to electricity as the main heating fuel changes increases the risk of high heating bills.

The assessment of running costs is challenging though as it is based on assumptions which are highly variable and also the subject of debate. Questions arising include: *Should maintenance costs be included? Which utility prices should be used? What should be the assumed lifetime of the system? What should be the level of the service charge? Should the results be expressed in £/year or £/kWh? Should the assessment be based from the perspective of the energy system operator or the resident?*

### 6.4.1 Adopting the perspective of residents: justification and approach

Only a few studies into the impact of the heating system on running costs have been completed, primarily to inform policy decisions. They tend to include all costs (e.g. capital costs, energy costs, etc.) and express the total cost in a single metric: the 'levelised cost of heat'.

As our concern in this section is the impact of heat pump systems on the budget of residents and how much they will have to pay to run a heat pump system, we have adopted the perspective of residents living in an energy efficient new build 2-bedroom apartment of 70 sqm using approximately 4,200 kWh<sup>24</sup> per year for heat (i.e. space heating and hot water), equivalent to 60 kWh/m<sup>2</sup>/year.

The perspective of residents also has the advantage of leading to an analysis which can be easily understood and interrogated. The assumptions and results are summarised to facilitate their review and a sensitivity analysis was undertaken to test the impact of various key parameters. Please refer to Appendix K for the full summary of the heating cost assessment.

### 6.4.2 Heating systems considered

The main aim of this analysis is to investigate the impact of a change towards heat pump based solutions. Three scales of systems have therefore been considered and seven heating systems in total.

#### Small/individual scale:

- individual gas boiler
- direct electric
- [individual air source heat pump](#)

#### Communal/building scale:

- communal gas boiler
- [communal air source heat pump](#)
- [communal ground loop individual heat pumps](#)

#### District/large scale:

- district heating with gas-fired boilers and CHP
- [district heating with heat pumps](#)

The non-heat pump systems were investigated in order to provide points of reference.

---

<sup>24</sup> Please note that this level of heating consumption represents a reasonably energy efficient apartment. An average 2-bedroom apartment would use 50% or more heat and a Passivhaus apartment approximately 30-50% less heat. These cases are considered in the sensitivity study undertaken as part of this assessment.

### 6.4.3 Heating cost components: structure

When looking only at the energy cost component (i.e. the direct costs related to metered energy use for space heating and hot water) a simplistic comparison of predicted future heating bills between systems may seem the right approach but it can be misleading. The reason for this is that, depending on the scale of the system, some costs are embedded in the heating bills. For example, whereas the heating bill for an individual gas boiler only includes the cost of the gas consumed and the standing charge for the gas connection, the heating bill associated with a district heating system generally includes all other costs (e.g. maintenance, replacement, etc.). It is therefore very important to be clear about what the heating cost comparison includes.

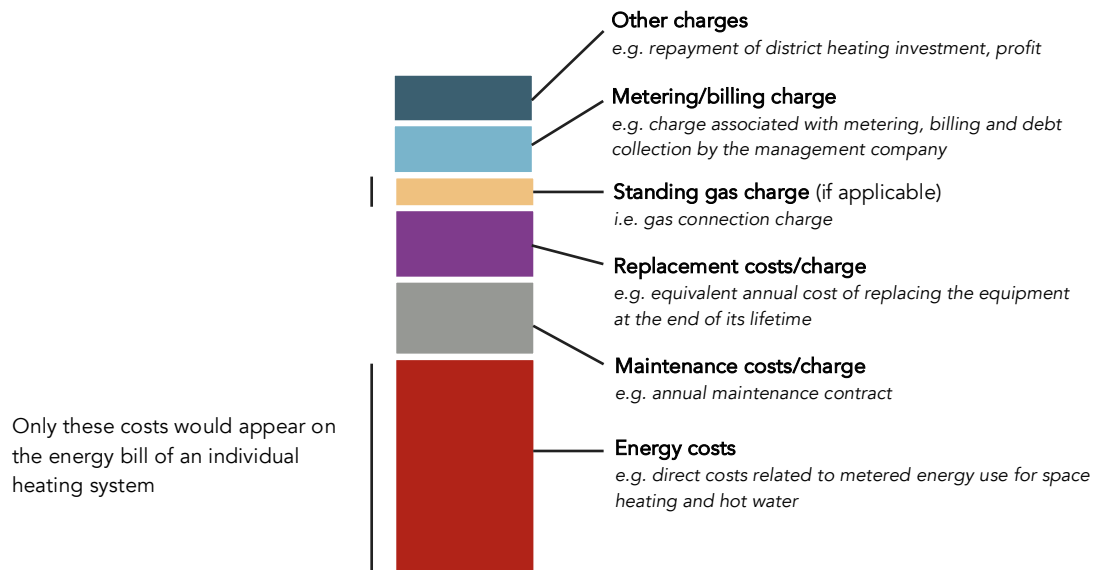

Figure 6.08 - Key components of heating costs

- **Energy costs** represent the proportion of the bill associated directly with energy used for heating and hot water. For district heating systems, this component is more complex as it includes distribution losses but also revenues from energy sale (e.g. electricity from CHP) and savings achieved through the purchase of gas and electricity at a wholesale price.
- **Maintenance costs/charges** include the annual average costs for maintenance. There is a significant variation even for a similar system depending on the approach to maintenance and the organisation responsible for it. A reasonable average between various sources was considered for this assessment.
- **Replacement costs** will incur at the end of life but communal systems generally annualise these costs in a sinking fund. A similar approach was therefore assumed for individual systems.
- The **Standing gas charge** would only apply when the resident needs an individual gas connection (i.e. individual gas boiler scenario).
- The **Metering/billing charge** is needed to pay for the maintenance of the heat meter, data gathering and, most significantly, billing and debt collection. These costs can be very significant and would not apply to individual systems.
- **Other charges** generally relate to the particular structure of district heating bills and finance. Contrary to individual and communal systems, most district heating costs are generally borne by the district heating operator which will have to recoup its investment (and make a profit) through the heating charge.

The matrix below indicates which cost elements generally form part of the resident’s energy bill.

	Individual system	Building level system	District level system
Energy costs	•	•	•
Maintenance costs/charges		• (not in all cases)	•
Replacement costs		• (not in all cases)	•
Standing gas charge	• (gas systems only)	• (gas systems only)	•
Metering/billing charge		•	•
Other charges			•

**Table 6.09 – Cost element likely to appear on the residents’ energy bills depending on system scale**

#### 6.4.4 High level assessment of heating costs

The figure below summarises the high level assessment of heating costs covering the key components shown in Fig. 6.08. An error bar has been added to each bar to indicate the approximate margin of error, which generally increases with the scale of the system given the variety of costs and systems available. Please refer to Appendix K for further details.

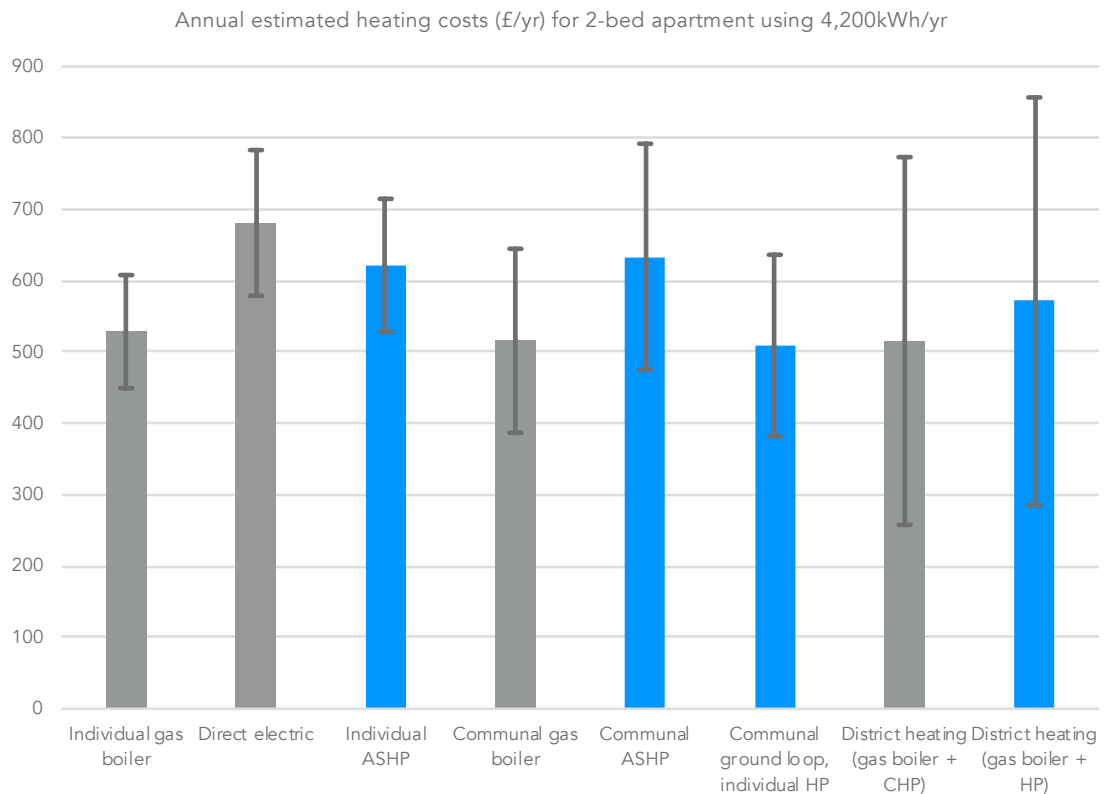

**Figure 6.09 - Comparison of predicted heating costs for the resident(s) of a 2-bed energy efficient apartment**

The bar chart above indicates that typically heat pumps are likely to lead to a small increase in annual heating costs compared to the cheapest non-heat pump solution (communal gas boiler, however, a communal ground loop with individual heat pumps is the cheapest overall and is very efficient. It is important to note that:

1. The costs associated with a communal air source heat pump system ('Communal ASHP below') will be lower if electricity is purchased at a cheaper rate.
2. The costs of metering and billing are an important component of all communal and district scale systems and should be reduced to a minimum to maintain low heating costs.
3. At the district scale, 'other charges' can be significant and our analysis suggests that they should be kept to a maximum of £100/year for an average 2-bed apartment in order for heating costs to remain competitive.

A number of sensitivity analysis were also undertaken and two of them are summarised in this section:

- What if the apartment is less efficient, i.e. if it uses more heat than predicted?
- What if utility prices increase?

**Impact of energy efficiency**

The figure below represents the impact of an increased heating demand (e.g. 7,000 kWh rather than 4,200 kWh assumed in the baseline). This would be representative of an average 'poor construction quality' new build apartment.

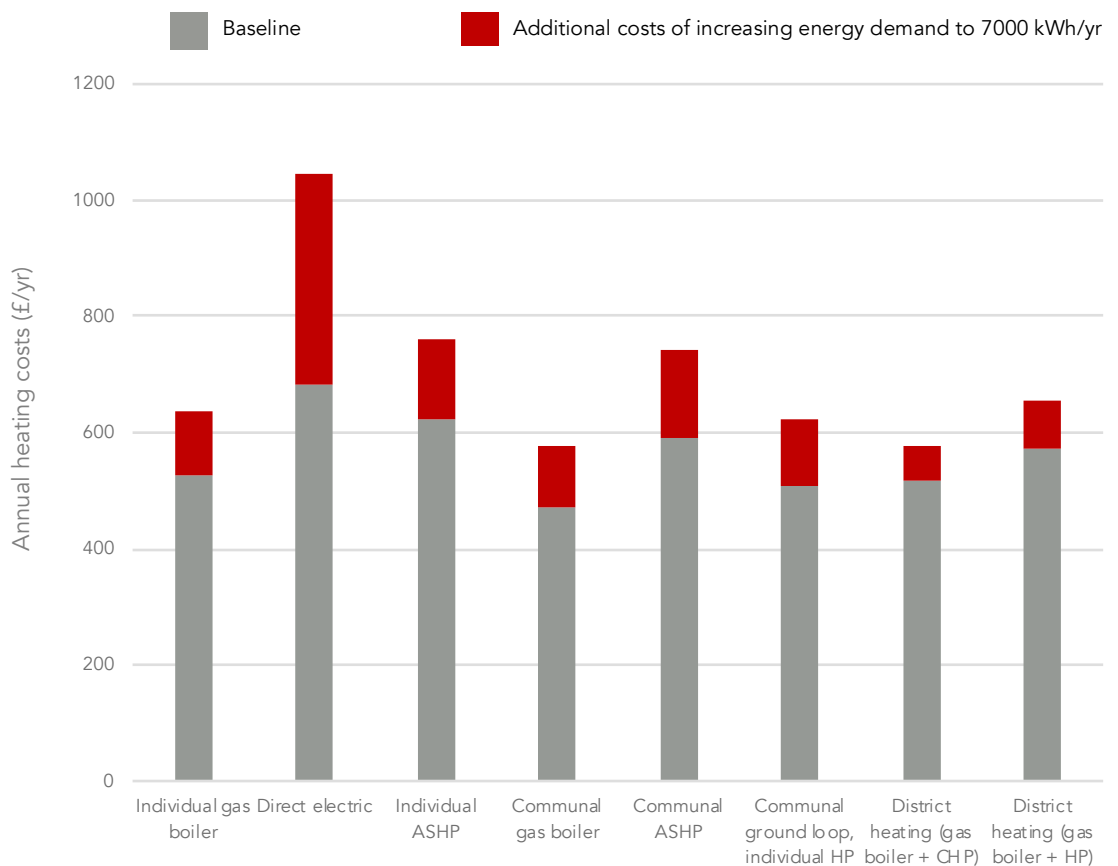

**Figure 6.10 - Impact of increased energy demand on likely heating costs**

An increase in heating demand would negatively impact the direct electric systems' heating costs to a greater extent as electricity has a high unit cost. In this case the increased demand has almost a proportional effect and it adds more than 50% to the heating costs

This effect is mitigated in heat pump based systems as the efficiencies of heat pumps mean the electricity required to meet the heating demand is significantly less.

**Impact of utility prices**

The following figure below represents the impact of an increase of all utility prices used in the baseline comparison by 30%. This analysis was undertaken to assess the exposure of residents to increases in utility prices in the future, which is a potential scenario<sup>25</sup>.

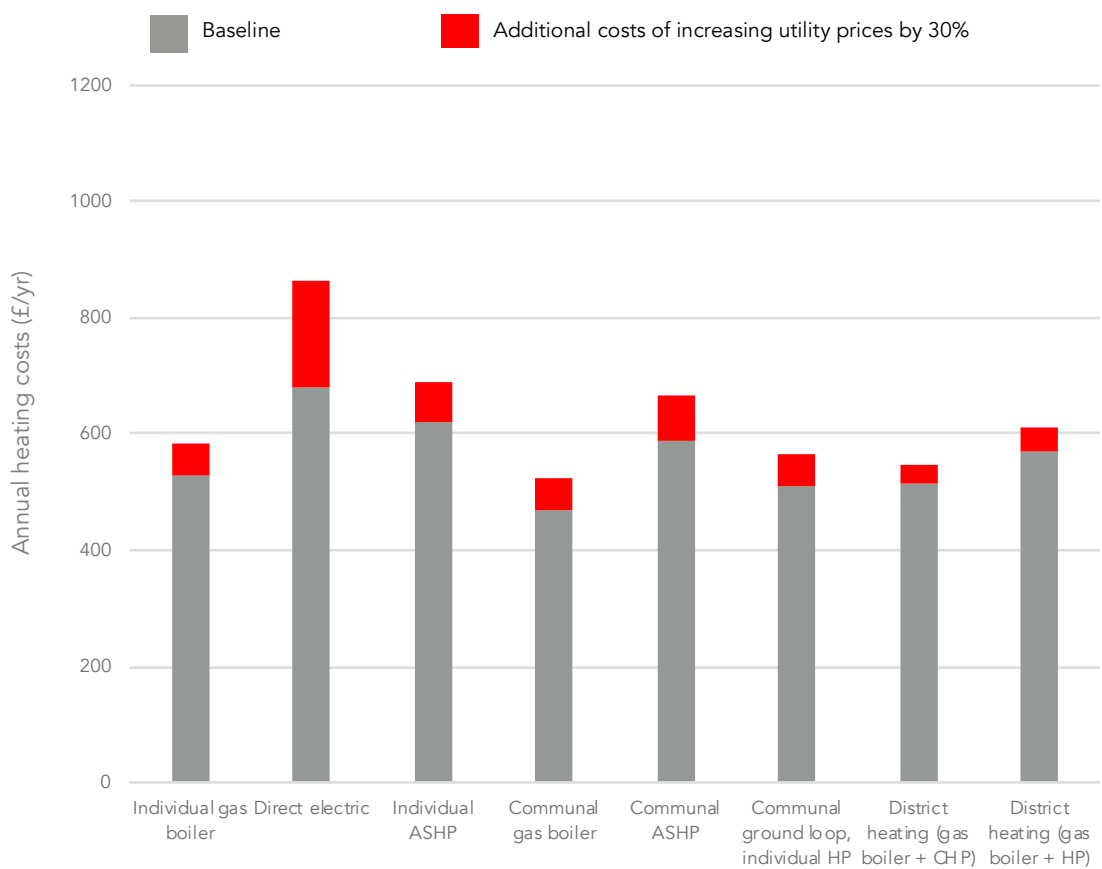

**Figure 6.11 - Impact of utility price increase on likely heating costs**

In summary:

- Electricity based systems will be more affected than gas-based systems as they use electricity as the main fuel (a 30% increase in electricity price will have a larger impact in absolute terms than a 30% increase in gas price);

<sup>25</sup> Electricity prices increased by approximately 30% between 2010 and 2018 (see fig App K-09)

- The effect on heating costs of direct electric systems will be most significant as the proportion of direct energy costs is much higher;
- The effect is reduced at a large scale when systems benefit from cheaper utility prices and therefore smaller increases in absolute terms.

6.4.5 Estimated impact of the Renewable Heat Incentive (RHI)

The Renewable Heat Incentive (RHI) can have a significant impact on heating costs. Assuming that 100% of the RHI savings are beneficial to the residents directly (e.g. individual air source heat pump) or passed on to residents in communal and district scale heat pump systems (for which commercial RHI tariff rates have been assumed), the following figure illustrates its likely impact on heating costs.

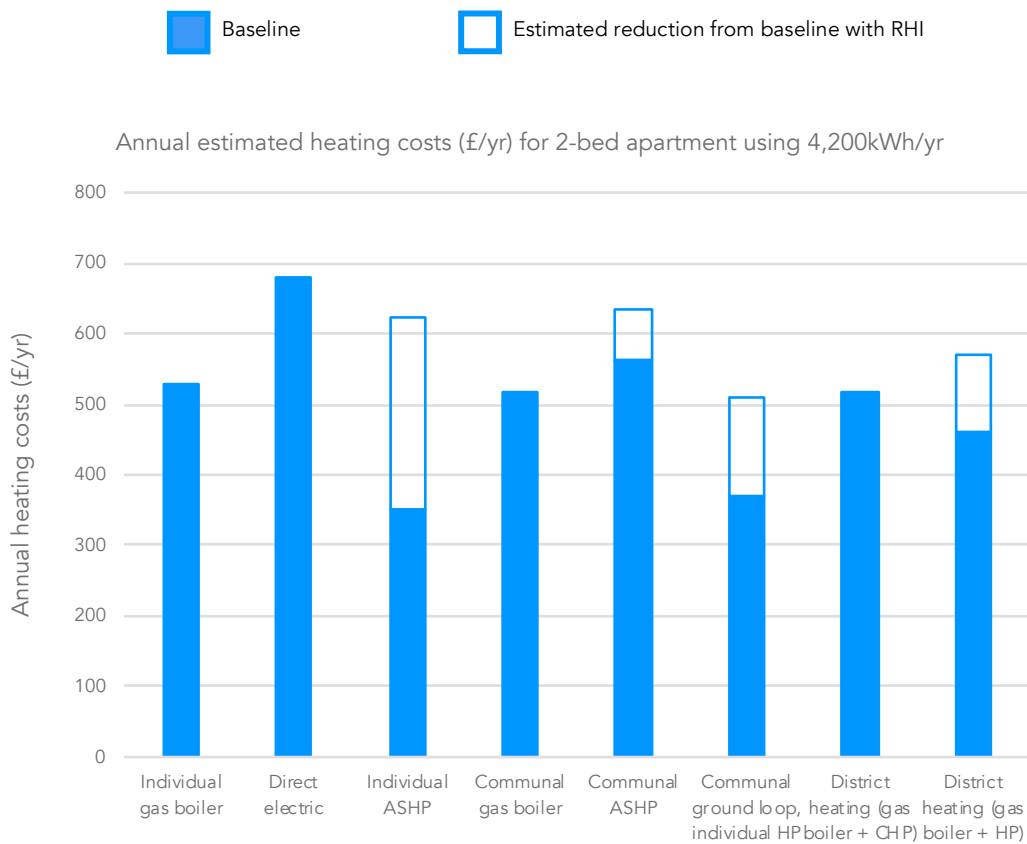

Figure 6.12 - Impact of RHI on likely heating costs for a 2-bed energy efficient apartment

As it can be seen, the RHI would have a positive to very positive impact on residents’ heating costs. With the RHI, individual air source heat pumps and the communal ground loop with individual heat pump systems would become the two most economic systems for residents. Heating costs of individual air source heat pump systems would become the lowest (circa £350/yr). If passed on to the residents, the benefit of the RHI would be to bring the annual heating costs to £380/yr (communal ground loop with individual heat pumps) or £570/yr (communal air source heat pump system).

Passing on the RHI benefits to the residents is however not the norm for communal systems as it is generally used to help finance the capital costs of the system.



## 6.5 Impact on space





Similarly to the capital cost assessment, estimating the impact of space is very dependent on the type of building and the type of heat pump system.

The impact of heat pumps in terms of space can be split up into three categories:

- **Building plant space** (including roof space): the impact of heat pump systems on communal plant space can vary significantly. Communal air source heat pump systems would generally require more space than a connection to an existing district heating scheme (i.e. + 35-40 sqm although some of this space can be located at roof level<sup>26</sup>). An approach based on a ground loop and individual water-to-water source heat pumps in each unit would, on the other hand, save approximately 15 sqm in communal plant space requirements.
- **Communal space**: the impact on riser space is negligible.
- **Apartment space**: space requirements of heat pump-based solutions depend on the hot water strategy (i.e. requirement of a hot water cylinder or not) and on detailed design (e.g. ability to combine elements in the utility cupboard). Our initial analysis indicates that the impact is likely to be marginal. It is very important to note that heat pump systems are very versatile, and that design can be modified in order to reduce the impact on internal space.

---

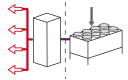
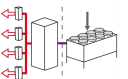
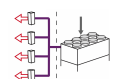
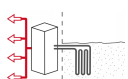
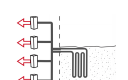
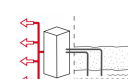
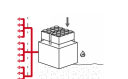
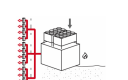
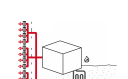
<sup>26</sup> The roof space requirement will vary significantly depending on the building type, scale and design. This could have an impact on the roof space available for PVs.

Type	Ref	Example	Additional space implications		
			DH Energy Centre	Building	Dwelling
AIR SOURCE Small-A1		Monobloc			External space required (e.g. balcony)
AIR SOURCE Small-A3		Hybrid			External space required (e.g. balcony) and in unit ~1sqm
AIR SOURCE Small-A4		Compact unit Heat Pump + MVHR			Space required in unit ~1sqm
AIR SOURCE Medium-W1		Communal air source heat pump to heat interface units (HIUs)		Additional ventilated or open-air plant room*	
AIR SOURCE Medium-W2		Communal air source heat pump to heat pumps		Additional ventilated or open-air plant room*	Space required in unit ~1sqm
AIR SOURCE Medium-W3		Communal VRF system air source heat pump to individual heat pumps		Additional ventilated or open-air plant room*	Space required in unit ~1sqm
GROUND SOURCE Medium-G1		Communal closed-loop ground source heat pump to heat interface units (HIUs)			
GROUND SOURCE Medium-G2		Communal ground loop connected to individual heat pumps		-	Space required in unit ~1sqm
WATER SOURCE Medium-W1		Communal water source heat pump to heat interface units (HIUs)			
AIR SOURCE Large-A1		DH network with primary air source heat pumps	Significant additional space with access to external air		
AIR SOURCE Large-A2		4 <sup>th</sup> generation DH network with air source heat pumps and heat pump in each building	Significant additional space with access to external air		
GROUND SOURCE Large-G1/2		4 <sup>th</sup> generation DH network with ground source heat pumps and heat pump in each building			
WATER SOURCE Large-W1/2		DH network with primary water source heat pumps			

**Table 6.10 – Qualitative appraisal of additional space requirements for a medium density apartment block**

\*The ventilated plant room could be located on the roof and not enclosed but this solution is unlikely in apartment blocks with competing uses for the roof (e.g. amenity) and potential noise considerations

# 7.0

## REVIEW OF KEY CONSIDERATIONS AND RISKS

---

According to the responses to the surveys and our literature review, the key risks associated with a wider uptake of heat pumps appear to be:

1. Installation quality
2. Commissioning
3. Visual impact
4. Noise (for air source heat pumps only)

Our analysis of these risks concluded that none of them are significant barriers but that the design has to be right.

The majority of refrigerants currently used in heat pumps have a high global warming potential and can present other risks. However, regulatory frameworks are in place. The use of low GWP industrial gases and HFOs, combined with the minimisation of refrigerant volumes will be important approaches to mitigation.

## 7.0 REVIEW OF KEY CONSIDERATIONS AND RISKS

This section addresses some of the key concerns associated with the wide spread deployment of heat pumps in the London area.

We asked participants in the surveys to express whether they thought that the following factors were a **low**, **medium** or **high risk**. Results based on 81 participants are illustrated visually below. The areas where participants have expressed high levels of concerns (e.g. design and installation) are examined in more details in the following sub-sections.

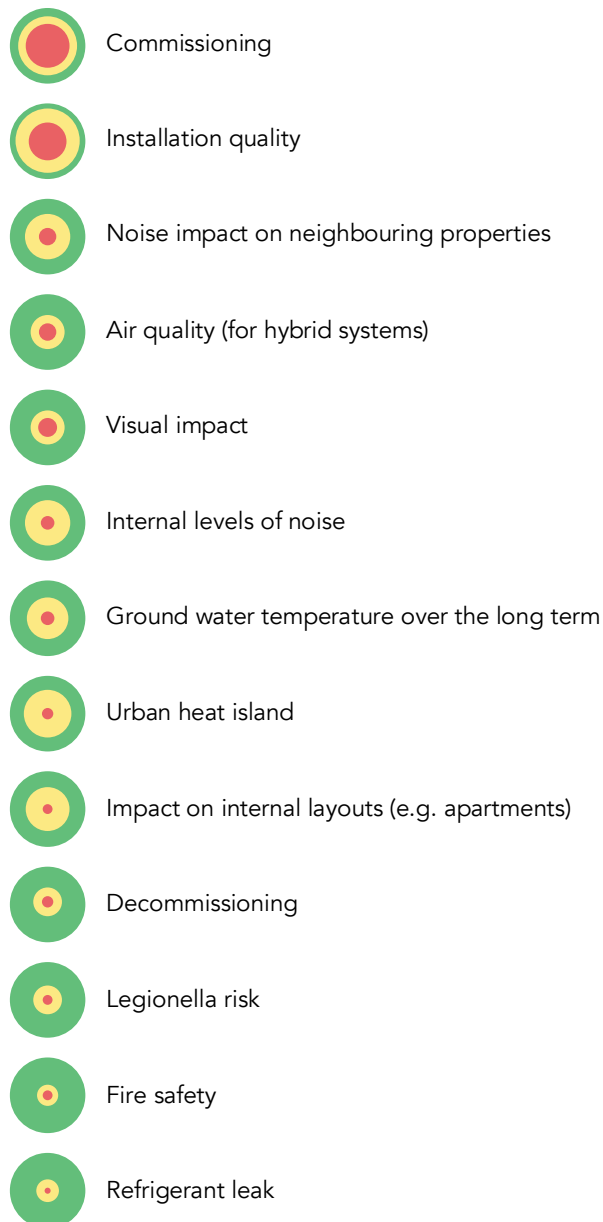

## 7.1 Refrigerants

Refrigerants perform a crucial role in the operation of heat pumps, transferring thermal energy between different parts of the system. Selecting a refrigerant for a particular application involves balancing a range of competing requirements for performance, safety, environmental impact and cost. Chemical researchers have claimed there are no new molecules that could satisfy the requirements for an ideal refrigerant<sup>27</sup>, so selection is largely a process of assessing known refrigerants and developing technology to work within their limitations.

The main environmental issues associated with refrigerants are climate change and depletion of the ozone layer. The latter has largely been addressed through global regulation of ozone depleting refrigerants, while efforts to reduce the use of refrigerants with high global warming potential (GWP) are now the main focus of regulatory development. Historically, the use of refrigerants falls into five distinct phases, which are outlined in Table 7.01.

Period	Refrigerants	Context
1800 – 1920's	Industrial chemicals such as ammonia, methyl chloride, sulphur dioxide, carbon dioxide.	None offered ideal characteristics. Methyl chloride and sulphur dioxide are highly toxic, ammonia is also toxic, carbon dioxide requires high pressures.
1930's	CFCs such as R11, R12, R113 and R114 introduced.	Reduced toxicity of CFCs led to rapid uptake. Strong ozone depleting potential and global warming effect (R12 has a GWP of 10,900). These were not considered until 1980's.
1950's	CFC costs reduced through improved synthesis. HCFCs such as R22 introduced.	R22 had a reduced but globally significant ozone depleting effect relative to CFCs. Montreal Protocol agreed in 1987 begins phase out of CFC's and HCFC's.
1990's	HFCs such as R134a and blends such as R410a.	Chlorine containing compounds that cause ozone depletion phased out as a result of the Montreal Protocol. Awareness slowly shifts to global warming potential.
2008 – Present	HFOs and HFO blends such as R1234yf, 1234ze and R513a. Industrial chemicals such as ammonia, carbon dioxide and hydrocarbons	Global efforts now focused on reducing use of refrigerants with high GWP. Kigali Amendment and EU F-gas regulations formalise commitment to phase out high GWP refrigerants.

**Table 7.01 – Historical development of refrigerants**

The regulation of refrigerants began with the Vienna Convention for the Protection of the Ozone Layer, which was agreed at the 1985 Vienna Conference. The Montreal Protocol to the Vienna Convention was agreed in 1987 and entered into force in 1989. A range of scientific analyses have since suggested the protocol has been effective in limiting the release of ozone depleting substances into the atmosphere. The Protocol had a unique adjustment provision that enabled parties to react quickly to new scientific information. This has subsequently resulted in eight revisions, with the most recent being the Kigali Amendment, which comes into force in 2019. The Kigali Amendment is focused on reducing global warming due to refrigerant gases through a managed phase-down by 2050.

<sup>27</sup> GF Hundy et al (2016) *Refrigeration, Air Conditioning and Heat Pumps*. Oxford, UK

Recent regulation of refrigerant gases in the UK has been achieved through implementation of EU-level regulations that have been transposed into UK law. The first F-gas regulation was introduced in 2006 and principally focused on leak reduction, with some end uses banned. A revised version was passed in 2015, which introduced a more comprehensive approach, limiting the amount of key F-gases that can be sold in the EU as shown in Figure 7.01. The regulation also extended prohibitions of F-gases where suitable alternatives exist and requires checks, servicing and F-gas recovery at the end of equipment life.

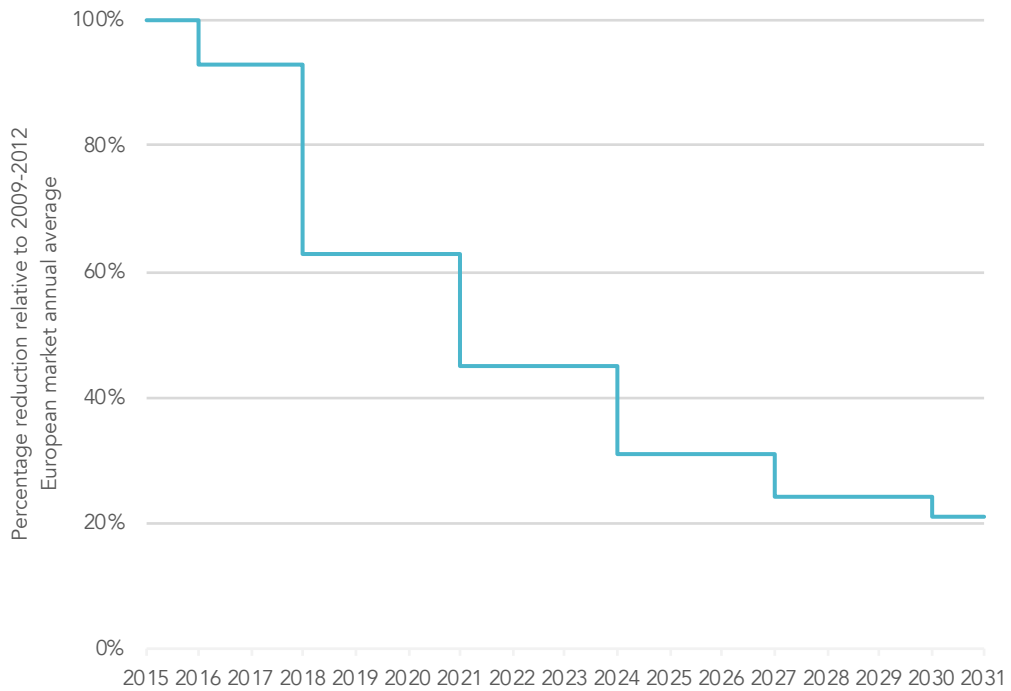

**Figure 7.01 – Refrigerant phasedown relative to 2009-2012 baseline required by EU Regulation 517/2014**

Regardless of the UK’s future membership of the EU, the UK has already ratified the Kigali Amendment and the EU F-gas regulations have been transposed into UK law. This has established a responsible approach to reducing the global warming potential of refrigerants, which is unlikely to change in the future as the fundamental approach is technically sound. The EU level regulations will also continue to affect the heat pump industry at an EU level, which is likely to influence refrigerants used in products sold to the UK.

The potential of refrigerant gas leaks on the global warming impact of heat pumps should be viewed within the context of both embodied emissions from manufacturing, operational emissions from the consumption of electricity and the relative emissions of competing combustion-based heating technologies. A comprehensive study<sup>28</sup> carried out by the former Department for Energy and Climate Change (DECC) concluded that greenhouse gas emissions due to refrigerant leakage represented “a small proportion of the total reduced emissions associated with heat pump technologies”.

<sup>28</sup> DECC (2014) *Impacts of Leakage from Refrigerants in Heat Pumps*.

The study predicted that the overall warming impact of refrigerants in 2050 will be 79% less than in 2020 as a result of the switch to lower GWP refrigerants, despite a substantial increase in the number of heat pumps to over 4 million units. The negative impact of refrigerant leakage was found to be only 0.65% of the calculated benefits of heat pumps. The study concludes by recommending that short-term measures focus on reduction of refrigerant leakage, while longer-term measures should incentivise low GWP refrigerants.

Heat pump manufacturers indicated in their survey responses that common refrigerants used in their heat pumps today include medium GWP refrigerants such as R410a, R407c, R417a and R134a, with some already using lower GWP refrigerants such as R32 and industrial gases such as R290 (propane) and R744 (carbon dioxide). In the future, all expect to use R32, particularly for air-air units, which are already starting to replace R410a based units. Increased use of industrial gases such as R290, R744 and HFOs such as HFO-1234ze, HFO-1233zd and R513a is planned for air-water and ground source heat pumps.

Interviews with heat pump manufacturers revealed a trend toward minimisation of refrigerant volume and leak potential achieved by a shift toward compact hermetically sealed heat pumps that use water as a heat transfer fluid, rather than refrigerant. This approach also circumvents a range of health and safety concerns associated with the circulation of refrigerant through buildings. Use of R744 (carbon dioxide) and R290 (propane) in these systems was being pursued by several manufacturers, with R744 being particularly well suited to the higher temperatures typically required for providing sanitary hot water. As R32 has a GWP of 688 it is unlikely to offer a long-term solution, therefore the use of truly low GWP industrial gases and HFOs, combined with minimisation of refrigerant volumes will be important approaches to mitigation.

## 7.2 Noise impact

The impact of heat pumps in terms of noise is again very dependent on the type of heat pump systems, its location and design.

The following table (Table 7.02) indicates the instances in which a noise impact is likely compared to a District Heating with CHP baseline for a medium density apartment building.

The impacts have been split up into three categories:

- Noise impact on the local environment;
- Noise impact on adjacent properties;
- Noise impact on the residential unit itself.

It should be noted that there are solutions to address these issues (e.g. acoustic screening) and that many types of heat pumps (e.g. individual exhaust air source heat pumps, ground source heat pumps) would not create any noise issue.

Type	Ref	Example	Potential noise impact		
			Local environment	Adjacent units	Dwelling
AIR SOURCE Small-A1		Monobloc	●	●	
AIR SOURCE Small-A3		Hybrid	●	●	
AIR SOURCE Small-A4		Compact unit Heat Pump + MVHR			●
AIR SOURCE Medium-W1		Communal air source heat pump to heat interface units (HIUs)	●	●	
AIR SOURCE Medium-W2		Communal air source heat pump to heat pumps	●	●	●
AIR SOURCE Medium-W3		Communal VRF system air source heat pump to individual heat pumps	●	●	●
GROUND SOURCE Medium-G1		Communal closed-loop ground source heat pump to heat interface units (HIUs)			
GROUND SOURCE Medium-G2		Communal ground loop connected to individual heat pumps			●
WATER SOURCE Medium-W1		Communal water source heat pump to heat interface units (HIUs)			
AIR SOURCE Large-A1		DH network with primary air source heat pumps	●		
AIR SOURCE Large-A2		4 <sup>th</sup> generation DH network with air source heat pumps and heat pump in each building	●		
GROUND SOURCE Large-G1/2		4 <sup>th</sup> generation DH network with ground source heat pumps and heat pump in each building			
WATER SOURCE Large-W1/2		DH network with primary water source heat pumps			

Table 7.02 – Qualitative appraisal of the risk of noise impact for a medium density apartment block



## 7.3 Design integration

### 7.3.1 Architectural

Levitt Bernstein Architects have prepared a list of potential architectural challenges and design considerations associated with the widespread uptake of heat pumps in London<sup>29</sup>.

**Implications for layout and space in homes.** The homes designed and built in London are built to the nationally described space standards. While this standard sets a minimum area for homes and some of their rooms inside, it is quite often used as the maximum financially viable size for homes. The space standards allow a degree of overall flexibility by prescribing bedroom sizes and storage area within the overall area. The consequence of this is that any additional space required for mechanical services is often deducted from the remainder of the dwelling area - typically the living space. The area required for mechanical services will potentially differ for heat pumps compared to typical alternative systems. This would have a knock-on effect on the storage space provided if the size of equipment increases post-planning, therefore reducing the dedicated storage area.

**Location size and access of internal equipment.** There may be a preferred location for the equipment in the home, for example near to a corridor or front door, or away from rooms such as bedrooms. Access for occupants to use or change settings and maintenance teams to maintain also need to be considered.

**Location size and access of external equipment.** The location of any external equipment has the potential to compete with the location of roof mounted solar panels, roof terraces and/or green roofs. Alternative locations of equipment on balconies or ground floors are likely to require visual and acoustic screening. Understanding the spatial, acoustic and visual considerations of external services is necessary given the risk of including visually intrusive equipment externally, when viewed from the street and adjoining buildings.

**Category 3 wheelchair accessible housing.** For wheelchair accessible homes equipment and controls are required to be within reach. Therefore, the conventional installation of equipment may not be suitable resulting in an increase in cupboard size.

**Size and positioning of mechanical service risers.** If there are any additional considerations for the size of service risers, above and beyond typical alternative systems this would need to be considered based on servicing arrangements in various apartment typologies - corridors, decks or between houses.

**Any wider impacts on dwelling layout.** The effect on other uses such utility cupboards, location of washing machines, fire proofing, refrigerant leaks and for special dwelling types (student housing, older peoples housing and shared living) and difficult corner flats should be considered.

It is recommended that these considerations are investigated in more detail as solutions representing good practice exist.

---

<sup>29</sup> These are not the result of any detailed work undertaken by Levitt Bernstein but the outcome of an initial thinking process kindly and voluntarily undertaken by them.

### 7.3.2 Mechanical and electrical design

One of the main obstacles towards the widespread adoption of heat pump technology, especially on a large scale, is that its design and integration is considered to be more technically challenging and 'risky' than for a gas boiler or a CHP. This is often due to the complexity of installing underground infrastructure (e.g. boreholes, wells, etc.) and also the issue of overcoming the relatively low heat generation temperatures that are below the normal LTHW supply temperatures most buildings require (particularly new buildings). Another difficulty that mainly applies to air source heat pumps is the variability of performance as the external temperature changes. This often results in the heat pump operating least efficiently when heat is most needed. To an extent, many of these difficulties are overcome when using a small scale packaged heat pump units for individual dwellings (e.g. houses): these modern heat pump units are normally self-contained systems that can switch between providing space heating efficiently at lower temperatures of 30-45°C and providing hot water at 65°C, albeit at a lower efficiency. When designing and installing heat pump systems for medium or large-scale developments, a different approach to just providing a hot water loop at a high temperature should be considered. A high temperature hot water loop would reduce the efficiency of the heat pump system.

It should also be noted that unlike gas boilers or CHP, there are not usually any inherent efficiency advantages to using large capacity heat pumps, although some types of heat pumps may only be available in larger sizes. A small heat pump with the same operating conditions will normally be able to operate at the same, or a very similar efficiency, to that of a larger unit. In fact, there may be efficiency benefits by having smaller heat pumps at the point of use that take low grade heat from a low temperature distribution loop. This method would eliminate the usual heat distribution losses that normally occur in pipework when delivering hot water from a central plant area (and reduce the associated risk of overheating in communal areas). It would also increase opportunities for heat sharing on mixed use sites.

The following paragraphs provide a summary of several potential MEP design strategies that could utilise heat pumps in many larger scale development types:

#### **Air source heat pump with refrigerant distribution**

This strategy is already commonly in use within many mid-sized commercial developments that have a space heating and cooling requirement. This type of system is commonly known as VRF (Variable Refrigerant Flow) or VRV (Variable Refrigerant Volume) and consists of an external air source heat pump that connects to indoor heating/cooling terminals via refrigerant pipework. It is able to offer both energy efficient heating and cooling and can even transfer heat internally between different areas (e.g. transferring heat from an area that requires cooling to an area that requires heating). Hot water can be provided either through secondary cascading heat pumps (in the case of some residential systems) or VRF hot water modules (for some commercial buildings). There are specific requirements which apply to minimise the risks of refrigerant leaks.

#### **Air source or ground source heat pump with (low temperature) hot water distribution**

This system approach involves using centralised air source heat pumps to efficiently generate water at around 35-45°C, which is distributed around the building and used for space heating only. Due to the relatively low temperature of the water, either underfloor heating or fan coil units would be required to emit the heat rather than radiators. Hot water would either need to be produced locally via direct electric point-of-use heaters (in the case of buildings that have a low hot water demand), or potentially through secondary local water-to-water heat pumps that upgrade the supplied low temperature hot water to 65°C. The latter approach would be appropriate for a multi-tenanted residential building for example.

### Ground source heat pump with (high temperature) hot water distribution

Large developments, including mixed-use schemes and those with multiple residential buildings, commonly have a central energy centre that distributes high temperature hot water (at 70-80°C) throughout the site. Although this type of application is not ideally suited to heat pumps due to the high temperatures required, it is technologically possible and has been achieved in other countries such as Denmark. Several manufacturers are able to provide high thermal capacity heat pumps with 2-stage compressors that are able to upgrade low grade heat from ground loop boreholes (at around 10°C) to around 70-90°C.

However, it should be noted that the efficiency of these ground source heat pumps is not particularly high as they have an SCOP of around 2 to 2.5, after accounting for the ground loop pumps. Another efficiency disadvantage of this type of system is from the greater heat losses in the distribution pipework due to higher water temperatures.

It should also be noted that the most efficient high temperature heat pumps use ammonia as a refrigerant. This requires specially trained maintenance personnel to carry out any work of them due to Ammonia's toxicity risk (and flammability risk to a lesser extent).

### Ground source heat pump with ambient temperature water distribution

As an alternative to hot water distribution, a strategy more suited to the advantages of heat pumps would be to distribute water at approximately 10°C, straight from the borehole array. Small individual heat pumps within each dwelling would be able to feed off the ambient water circuit and generate space heating locally at an optimum efficiency temperature of 35°C for space heating, and switch to hot water at 60-65°C as required. This design strategy virtually eliminates distribution pipework heat losses and also enables the heat pumps to operate at a much higher efficiency at times when only space heating is required. Other advantages include:

- Heat interface units and heat meters not required for each dwelling;
- No central heating plant required (only pumps) allowing for a smaller plantroom;
- Lower cost distribution pipework;
- Minimal maintenance requirements.

## 7.4 Key risks and considerations

The following sections outlining the potential risks and considerations are ordered according to the levels of concern reflected in both the survey results and literature review.

### 7.4.1 Installation quality and commissioning

Correct design and installation of heat pumps has been highlighted as a key concern across all areas of the heat pump industry.

**Appropriate design and sizing is seen as the key challenge related to installation.** It is also agreed amongst installers we asked that good quality installation of heat pumps is more difficult to achieve than gas boilers. The field trials also found that heat pump design and heat loss calculations at the chosen flow temperature and proportion of space heating were poorly understood amongst installers.

**The number and quality of installers is a barrier for widespread heat pump deployment.** 80% of the suppliers from the survey agree that there is a skill shortage and lack of MCS certified installers. The results show that all suppliers provide installer training and that 80% of installers think the training they received from manufacturers was adequate. Still, there were many comments on the lack of capable installers with the technical expertise to commission large scale projects.

**Microgeneration Certification Scheme (MCS) is not sufficient.** The MCS only applies to dwellings and to commercial installations below 45kW<sub>th</sub>. Generally, many survey comments were also concerned about the fact that the MCS process focuses too much on paperwork and too little on actual installation quality. The MCS umbrella schemes should be specifically regulated and potentially expanded to cover larger installations.

#### 7.4.2 Maintenance

**Maintenance requirements for heat pumps vary depending on system type and manufacturer.**

Installers generally agree that heat pumps require lower maintenance than gas boiler, particularly if properly designed. Some ground source heat pump manufacturers offer 5-year warranties that do not require regular maintenance, while most manufacturers of air source heat pumps suggest an annual inspection is performed, which would typically include:

- Checking fault codes
- Checking wiring connections are tight, dry and not corroded
- Checking thermostat settings
- Visual check of outdoor unit if present
- Clean outdoor unit if necessary (remove leaves etc.)
- Check if owner is satisfied with system operation

**The supply chain for maintenance and repair does not appear to be well-established.** Since the market is not well developed to support failures involving replacement and repair, and any errors will negatively impact occupants particularly in residential developments, it has a knock-on effect on clients' confidence to deploy heat pumps despite having aspirations for low carbon heat. Survey results state that most suppliers certify companies to maintain their products, and some state they know of 100+ companies for maintenance in London area. However, this established maintenance support network does not seem to be reflected in the comments.

**Maintenance contracts maybe used as a revenue stream by some installation companies,** with some charging up to £500 for an inspection. Where an annual inspection is required, prices of £90-£300 are typical (to be compared with approximately £100 for an individual gas boiler), with the lower prices being offered by smaller companies that specialise in installation and maintenance.

**Main cause of failure is likely due to incorrect design, installation and commissioning.** Errors in electronic control systems or user operation of systems have also emerged as likely reasons for repair from the survey results. The majority of participants agrees that failures related to the compressor, corrosions and other corrosions related issues (e.g. refrigerant loss) are very rare. This was mirrored by industry feedback to operational issues they have encountered. The common theme was centred around design and control strategies, which inadvertently led to problems of providing enough heat at peak winter demands, or higher running costs from poor performance and excessive direct electric energy use. One comment emphasised that heat pumps are "ultra reliable and durable", and any issues are related to design.

### 7.4.3 Supply chain

**Heat pump manufacturers generally indicated that their supply chain was robust** and would be able to handle a significant increase in demand for heat pumps. Many heat pump manufacturers are large multinational companies, to whom the UK represents a relatively small market. Even UK based heat pump manufacturers source the majority of their components from large multinational manufacturers of compressors, pumps and heat exchangers, therefore any increase in demand in the UK market would be unlikely to represent a significant increase in demand to the component manufacturers.

**Concerns were generally more focused on the need to improve system design, installation and commissioning**, particularly in an expanding market. Manufacturers who carried out their own training expressed an ability to expand these programmes if necessary.

**A more specific concern from the ground source heat pump industry was the ability of borehole drilling companies to accommodate a rapid increase in demand.** This industry requires specialist equipment, training and skillsets, which are capital intensive and take time to develop. Stable long-term growth in demand is therefore likely to be necessary to encourage an increase in borehole drilling capacity. Unfortunately, the Renewable Heat Incentive has not delivered these conditions as a result of poor tariff configuration, with manufacturers indicating in some cases it had reduced demand as people opted for biomass systems over heat pumps.

### 7.4.4 Noise and Vibration

The Microgeneration Certification Scheme requires planning permission for air source heat pumps if noise pollution experienced by a neighbouring property could exceed 42dB(A), with calculations based on a background noise level of 40dB(A).

Small air source heat pumps typically produce around 40-55 dB(A) at a distance of 1m, with noise falling as distance increases. It is therefore unlikely that properly sited and installed heat pumps of this size will create a significant audible disturbance. Medium sized air source heat pumps produce more noise, typically around 60-90 dB(A), therefore their location must be considered more carefully.

A study on the acoustic noise of air source heat pumps (2011) highlights that there is little data available on in-situ noise emissions from operational heat pumps. The report based on 9 sites concludes that noise measurements are generally within the range of predictions derived from manufacturer's information, but product data sheets do not specify significant acoustic tones (i.e. low frequencies), which may contribute more to the acceptability of the noise pollution.

The survey results revealed a consensus that appropriate planning and acoustic treatment were required to manage impact. It was pointed out that poor maintenance, or potentially time shifting demand to night time will adversely affect noise pollution.

It should finally be noted that studies into the noise impact of chillers and VRF units are common practice, particularly for large commercial buildings. Noise from heat pumps would be addressed in a similar way.

### 7.4.5 Urban heat island

**Heat pumps in cooling applications may exacerbate urban heat islands**, but it is not expected to have a large impact until significant uptake. Generally, participants in the survey consider urban heat island as a low to medium risk. For heating, the heat "absorbing" nature of heat pumps to its surrounding sources in theory should not contribute to urban heat islands. More in-depth studies should be carried out on the effect of heat pumps on microclimates in cities.

#### 7.4.6 User / usability

**The lack of end-user understanding often leads to excessive use of secondary direct electric** (when there is a back-up electric immersion heater) **and increased running costs**. The consensus is that there is a need to provide the end-user with greater education on the control and operations of heat pumps, as most customers (including contractors) are unfamiliar with the lower temperature requirements and a continuous heating approach. This is reflected across the literature, whereby user-related control errors can be detrimental to a heat pump's efficiency. One particular study stated that some residents may feel that a 24-hour heating schedule is an unaffordable luxury.

#### 7.4.7 Legionella

**70% of the survey results considers legionella as a low risk factor**. The Health and Safety Executive (HSE) provides a guidance document<sup>30</sup> on how duty holders should manage legionella bacteria risks in hot and cold water systems. The exact strategy for control depends on the design and size of water systems. Generally for domestic hot water, the document advises water storage of at least 60°C and distribution at (or above) 50°C within one minute at the outlets. Additional control strategies such as regular water movement is recommended for large healthcare facilities.

**Heat pump specific legionella control strategy should be investigated**. Some field trials show that 25-40% of sites may have unsatisfactory best practice legionella control. The current temperature-based control method also impacts efficiency negatively. In one particular study, one of the sites adopted UV disinfection lamps for sterilisation, but its effectiveness on legionella was not thoroughly analysed.

#### 7.4.8 Other considerations

**Fire safety is considered as a low risk factor** by the survey results. Fire risks in heat pumps can stem from electrical faults or refrigerants if they are flammable. Typically refrigerants are only flammable upon contact with air, so preventing refrigerant leaks can help to increase fire safety. Regulations for F-gas include regular checks for leakage, with the frequency of checks based on the GWP.

**Decommissioning of heat pumps is considered as a low risk factor** by 60% of the survey participants. Comments from the remaining 40% relate to safe disposal, handling and recycling of refrigerant products at their end-of-life. It should be noted that there are existing regulations for the decommissioning of F-gases.

**Embodied energy should be considered not only in heat pumps, but in all solutions to deliver low carbon buildings**. In the continuous effort to minimise energy use and provide renewable heat, the operational carbon (CO<sub>2</sub> emissions associated with the day-to-day energy consumption of a building) will gradually decrease. Subsequently, carbon emissions associated with sourcing, manufacturing, repairing and disposing of a product (end-of-life) will become more important. Whole life carbon assessments should be carried out using the RICS guidance (Whole life carbon assessment for build environment) and investigating a product's carbon footprint outside of its operational carbon through documents such as EPDs (Environmental Products Declarations).

---

<sup>30</sup> <http://www.hse.gov.uk/pUbns/priced/hsg274part2.pdf>

# 8.0

**A P P E N D I C E S**



A

APPENDIX A





## APPENDIX A - HISTORICAL AND PROJECTED CARBON FACTORS FOR GRID ELECTRICITY

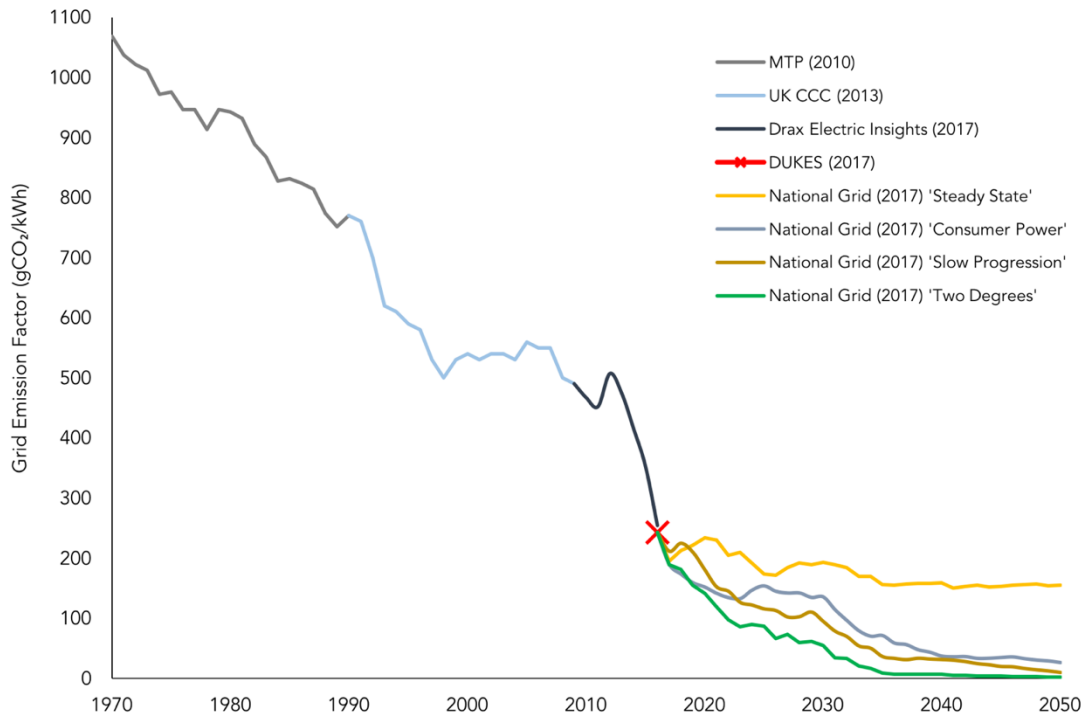

**Figure App A-01 – Historical and projected carbon factors for grid electricity (data corrected for continuity between sources)**

The **Market Transformation Programme (MTP)** data shows system average values for the years 1970-2005. This historical data provides important context on how rapidly emission reductions for electricity have been achieved in the past, principally through the retirement of coal fired power stations, which have been replaced with gas-fired power stations, nuclear generation and increasingly, renewable energy.

The **UK Committee on Climate Change (CCC)** data is taken from the 2013 Fourth Carbon Budget Review. This data is partially based on similar datasets to historic MTP data and is therefore shown overlaid on top of MTP data from 1990 onwards.

The **Drax Electric Insights** data is taken from the Drax Electric Insights web page, which is maintained by the Drax Group and uses data from Elexon and the National Grid. The methodology for acquiring, processing and presenting the data was developed by Dr. Iain Staffell of Imperial College London. The methodology has been written up as an academic paper and published in the journal 'Energy Policy'. The mathematics behind it have been independently reviewed by Dr. Grant Wilson, a leading UK academic.

The **Department for Business, Energy and Industrial Strategy's** single figure for 2016 from the Digest of UK Energy Statistics (DUKES) 2017 is provisional at the time this document is published. This figure is however broadly in line with other datasets including the Drax Electric Insights website and the National Grid's Future Energy Scenarios.

The **National Grid's 2017 Future Energy Scenarios** present four different scenarios for electricity supply and demand through to 2050. While these are not intended as predictions, they do represent plausible pathways for the UK's future electricity mix. In the majority of scenarios there is a consistent trend for rapid decarbonisation of electricity supplies between 2015 and 2020 due to the retirement of coal fired power stations. This is driven by a combination of the EU Large Combustion Plant Directive, the EU Industrial Emission Directive and the UK carbon price floor, all of which present an increasingly adverse regulatory and economic environment for coal power generation.

Whilst changes to these policies may affect the length of time the last few coal power stations in the UK remain open, there is a clear trend towards elimination of coal from the generation mix, with the Longannet, Ferrybridge C and Rugeley closures in 2016 removing around 4GW of coal capacity from the grid and more closures expected soon.

Post 2020, subsequent declines in carbon content occur at a reduced rate due to a more gradual replacement of lower emission gas-fired power stations with nuclear power stations and renewable energy. It is during this second phase of decarbonisation (from 200 g of CO<sub>2</sub> per kWh and below), that the scenarios diverge due to differing assumptions on the relative proportions of remaining fossil fuel generation capacity compared to low carbon sources such as renewables and nuclear.

B

A P P E N D I X B



## APPENDIX B - THE DIFFERENT TYPES OF HEAT PUMPS

### Small scale / individual heat pumps

The heat pumps in this category have generally a capacity of 0 to 20 kW and a refrigerant charge of 0 to 5 kg.

The main types are summarised in the table below.

Type	Ref	Examples	Description
AIR SOURCE	Small-A1	Monobloc	The whole heat pump is located externally in a small packaged unit. Heat from the heat pump is distributed internally with water (not refrigerant).
			
	Small-A2	Split systems	The heat pump is split into two units: an external one and an internal one. Refrigerant circulates between the two units.
			
	Small-A3	Hybrid split systems (with gas boiler)	Same as Small A-1 but with the addition of a gas boiler integrated with the system.
			
	Small-A4	Ducted Monobloc Exhaust air heat pump Compact unit Heat Pump+MVHR	The whole heat pump is located internally in a packaged unit. It can either be a ducted Monobloc (using external air) or an exhaust air source heat pump (using exhaust air). A Mechanical Ventilation with Heat Recovery (MVHR) can be integrated in the system.
			
GROUND SOURCE	Small-G1	Individual ground source heat pump	The ground is used as a heat source. It is coupled with an internal unit.
			

Table App B.01 – Types of small / individual scale heat pumps

Medium scale / communal heat pumps

The heat pumps in this category have generally a capacity of 20 to 170 kW and a refrigerant charge of 5 kg to 50 kg. The main types are summarised in the table below.

Type	Ref	Examples	Description
AIR SOURCE	<b>Medium-A1</b> 	Communal air source heat pump to heat interface units (HIUs)	Heat is generated by a medium-scale / communal air source heat pump. A water-based system is used to distribute heat around the building / to each unit where it is distributed either directly to emitters or via a Heat Interface Unit (HIU).
	<b>Medium-A2</b> 	Communal air source heat pump to heat pumps	Heat is generated by a medium-scale / communal heat pump. A water-based system is used to distribute heat around the building / to each unit where secondary heat pumps raise the temperature further.
	<b>Medium-A3</b> 	Communal air source heat pump to heat pumps (e.g. VRF)	A refrigerant-based system is used to distribute heat around the building / to each unit where secondary heat pumps extract heat from it.
GROUND SOURCE	<b>Medium-G1</b> 	Communal closed-loop ground source heat pump to heat interface units (HIUs)	Heat is generated by a medium-scale / communal closed-loop ground source heat pump. A water-based system is used to distribute heat around the building / to each unit (directly to emitters or via a HIU).
	<b>Medium-G2</b> 	Communal ground loop connected to individual heat pumps	A ground loop is supplying water to individual water-to-water heat pumps in each unit.
WATER SOURCE	<b>Medium-W1</b> 	Communal open-loop water source heat pump to heat interface units (HIUs)	Heat is generated by a medium-scale / communal open-loop water source heat pump (e.g. abstracting and rejecting water to the aquifer). A water-based system is used to distribute heat around the building / to each unit (directly to emitters or via a HIU).

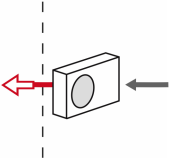
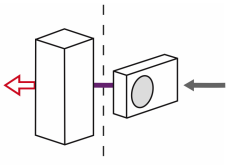
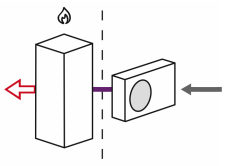
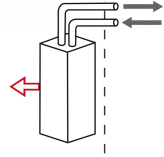
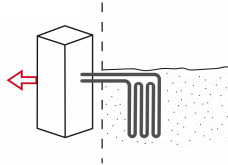
Table App B.02 – Types of medium / communal scale heat pumps

Large scale / district heat pumps

The heat pumps in this category have generally a capacity of more than 170 kW and a refrigerant charge of more than 50 kg. The main types are summarised in the table below.

Type	Ref	Examples	Description
AIR SOURCE	Large-A1 	Air source heat pumps supplying heat to a medium temperature DH network	Heat is generated by a large-scale air source heat pump system used in conjunction with other systems (e.g. central gas boilers). Heat is distributed to heat substations in each building.
	Large-A2 	4 <sup>th</sup> generation DH network with air source heat pumps and secondary heat pumps in each building	Heat is generated by a large-scale air source heat pump system potentially used in conjunction with other systems (e.g. central gas boilers). Low temperature heat is distributed to secondary heat pumps in each building/unit.
AIR SOURCE	Large-A3/4 	Tube exhaust air source heat pumps supplying heat to a medium or low temperature DH network	Variation of the systems above with heat generated by a large-scale air source heat pump extracting heat from the ventilation system of the tube.
GROUND SOURCE	Large-G1/2 	4 <sup>th</sup> generation DH network ground source heat pump and secondary heat pumps in each building	Variation of the systems above with heat generated by a large-scale closed-loop ground source heat pump.
WATER SOURCE	Large-W1/2 	Open-loop water source heat pump supplying heat to a medium or low temperature DH network	Variation of the systems above with heat generated by a large-scale open-loop ground source heat pump.

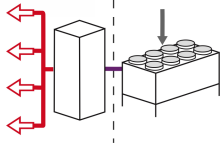
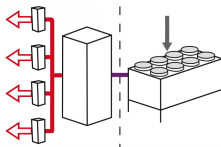
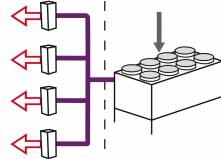
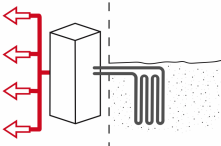
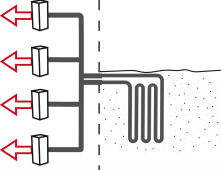
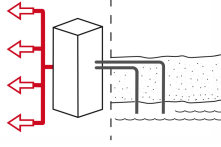
Table App B.03 – Types of large / district scale heat pumps

C

APPENDIX C

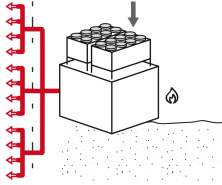
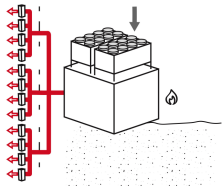
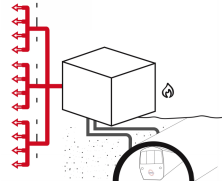
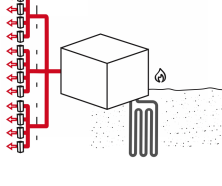
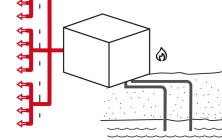

---

## APPENDIX C - HEAT PUMP EFFICIENCY BACKGROUND

The efficiency of a heat pump depends on a range of factors, some of which are fixed, while others change dynamically while the heat pump is operating:

- Heat demand (ie building fabric efficiency<sup>31</sup>)
- Refrigerant properties
- Compressor type
- Control algorithm
- Heat source temperature (ie climate data)
- Evaporator defrost cycles<sup>32</sup>
- Heat distribution temperature
- Heat source attributes<sup>33</sup>
- Relative proportions of heat demand for space heating and sanitary hot water
- Relative temperatures of fluid & gases in heat exchangers<sup>34</sup>
- System boundaries, which affect pump and fan energy use<sup>35</sup>, electric back-up heating and hot water tank losses.

A range of BS and EN standards have been developed that prescribe specific test conditions, which fix many of these variables, allowing consistent measurement and calculation of heat pump efficiency. One measure that has not been fully addressed by these standards is the definition of system boundaries (ie what parts of a heat pump system are included in efficiency calculations).

These efficiency metrics have been developed over several years at an EU level to cover the European market and enable the application of Ecodesign regulations across all member states. Regardless of the UK's future status as an EU member, these performance standards will continue to be used by the majority of manufacturers as they provide a consistent regulated approach to determining efficiency.

To address this, the European Heat Pump Association (EHPA) conducted a study from 2009-2012 called SEasonal PERFORMANCE factor and MONitoring for heat pump systems in the building sector (SEPEMO-Build).

---

<sup>31</sup> More efficient buildings do not require space heating until outdoor temperatures are colder, which counterintuitively results in lower heat pump efficiencies relative to less efficient buildings.

<sup>32</sup> These typically reduce the COP by 0.3-1.0, depending on the efficiency of algorithm.

<sup>33</sup> The conductivity of frozen ground is different to unfrozen ground, air humidity affects likelihood of evaporator freezing.

<sup>34</sup> Control algorithms for heat source and distribution systems affect the return temperatures of heat distribution fluids entering heat exchangers.

<sup>35</sup> These typically affect the COP by up to 0.3.



This resulted in the definition of four system boundaries, which have since been adopted in a range of studies and regulations:

1. Compressor only.
2. Compressor and external pump at the borehole heat exchanger (BHE)<sup>36</sup>.
3. Compressor, external pump at the BHE, internal pumps and back-up heating devices.
4. Compressor, external pump at the BHE, internal pumps, back-up heating devices, fan-coils and air-handling units.

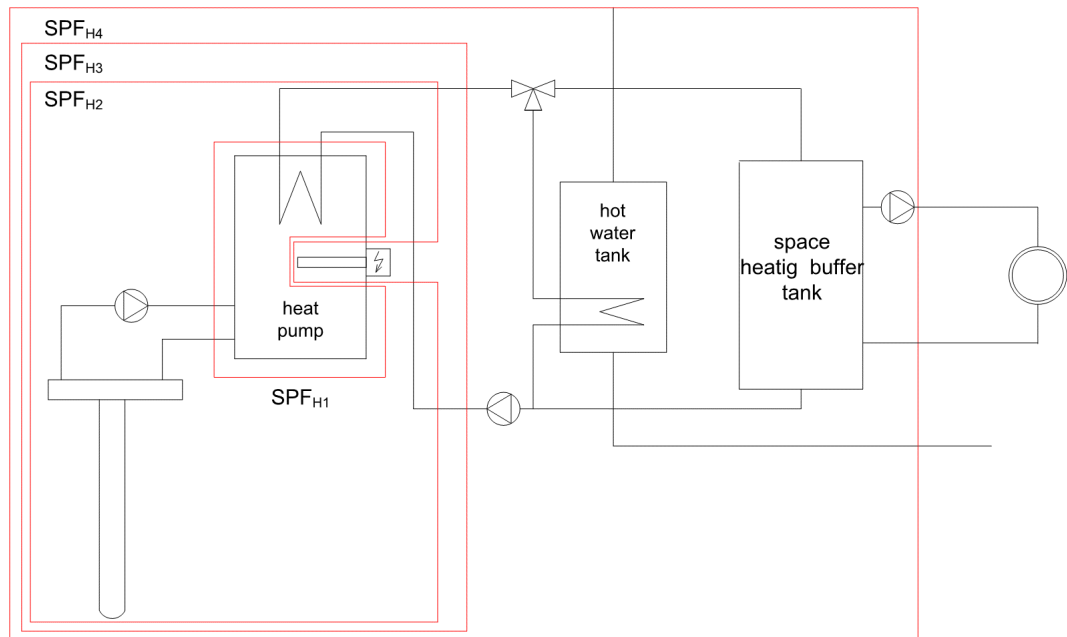

Figure App B-01 –Heat pump system boundaries as defined by the SEPAMO-Build project

A fifth system boundary was created by UCL Energy Institute in 2016<sup>37</sup>:

5. Compressor, external pump at the BHE, internal pumps, back-up heating devices, fan-coils, air-handling units and hot water tank losses.

<sup>36</sup> In terms of the estimates for renewable energy generated by HP systems in accordance with the EU Renewable Energy Directive, the EU Commission Decision of 1st March 2013 defines the relevant measure of efficiency to be SPFH2, i.e. the efficiency of the heat pump without the inclusion of electricity used for backup or for circulation and heat distribution pumps. The Directive considers electric heat pumps to be classed as a renewable energy source provided that  $SPFH2 \geq 2.5$ .

<sup>37</sup> UCL Energy Institute (2016) DECC RHPP Detailed Analysis Report.

D

APPENDIX D



## APPENDIX D - MEASURES OF HEAT PUMP EFFICIENCY

### Coefficient of Performance (COP)

The COP measures instantaneous efficiency in terms of power rather than energy consumption. It varies depending on the source and sink temperature, therefore these must be quoted for the COP value to have meaning. Manufacturers commonly quote COP values over a range of source and sink temperatures specified in EN14511. COP's can therefore provide a comparative indication of heat pump efficiency based on these standard test conditions. As long as the system boundaries are appropriate for the heat pump system being modelled, a dynamic calculation based on COPs over a range of temperature conditions may provide the most accurate indication of heat pump efficiency.

$$COP_{EN14511} = \frac{\text{heating power out (Watts)}}{\text{electrical power in (Watts)}}$$

The theoretical maximum COP of a heat pump may be calculated as follows:

$$COP_{max} = \frac{T_c}{T_h - T_c} \quad (\text{where } T_c = \text{cold temp, } T_h = \text{hot temp, in Kelvin (273.15c)})$$

The theoretical maximum COP for air-water heat pumps based on EN14511 temperature ranges are outlined in the table below:

Source temperature (°C)	Sink temperature (°C)			
	35°C	45°C	55°C	65°C
12°C	12.40	8.64	6.63	5.38
7°C	10.01	7.37	5.84	4.83
2°C	8.34	6.40	5.19	4.37
-7°C	6.34	5.12	4.29	3.70
-15°C	5.16	4.30	3.69	3.23

**Table App.D-01 – COP<sub>max</sub> based on EN14511 test conditions**

SEPAMO-Build defines the typical system boundary for COP<sub>EN14511</sub> testing as SPF<sub>2</sub>.

### Seasonal Coefficient of Performance (SCOP)

The SCOP provides an indication of the efficiency of a heat pump in terms of energy consumption over a typical season. It varies depending on the weather scenario that is assumed, how source temperatures are combined and averaged, and on the sink temperature. The EU Ecodesign Directive requires SCOP to be calculated based on the methodology prescribed in EN14825:2016. This provides a calculation procedure that uses EN14511 based COP measurements taken under known test conditions and assumed weather conditions. An important limitation of SCOP is the number of hours a heat pump operates at under each source temperature must be assumed. In reality, the space

heating demand will vary for each building depending on the temperature point at which heating is required.

$$\text{SCOP} = \frac{\text{total heat energy out per season}}{\text{total electrical energy in per season}}$$

For SCOP values to have meaning and be comparable, the assumed weather conditions and heat sink temperatures must be identical. SCOP values quoted without reference to this data are therefore of limited use.

The typical system boundary for SCOP calculations is SPF<sub>3</sub> according to SEPAMO-Build.

### Seasonal Performance Factor (SPF)

The SPF provides a real-world metric for heat pump efficiency within a specific building and climate. It is determined through analysing field trial data for operational heat pumps. While SPF generally offers a robust measure of heat pump efficiency, it shares the limitations of other efficiency ratings in terms of varying both on the outdoor temperature at which heating is first required, and with building fabric efficiency. Importantly, SPF is now calculated under the range of system boundaries developed by the SEPAMO-Build programme.

$$\text{SPF} = \frac{\text{total heat energy out per season (BTU)}}{\text{total electrical energy in per season (Wh)}} \quad (= \text{SCOP}_{\text{net}})$$

### Energy Efficiency Ratio (EER)

The EER measures instantaneous efficiency in terms of power rather than energy consumption for cooling. It varies depending on the source and sink temperature, therefore these must be defined for the EER value to have meaning. EER is calculated using different units for cooling capacity in North America (BTU) and Europe (Watts), and are not therefore directly comparable.

In Europe, the EER is calculated based on temperature conditions outlined in EN14511:2011

$$\text{EER}_{\text{EN14511}} = \frac{\text{output cooling power (Watts)}}{\text{input electrical power (Watts)}}$$

### Seasonal Energy Efficiency Ratio (SEER)

The SEER provides an indication of the efficiency of a heat pump in terms of energy consumption over a typical cooling season. It varies depending on the weather scenario that is assumed, how source temperatures are binned and averaged, and on the sink temperature. It is usually determined through calculations based on COP measurements taken under known test conditions and assumed weather conditions. An important limitation of SEER is that the number of hours a heat pump operates at under each source temperature must be assumed. In reality, the space cooling demand will vary for each building depending on the temperature point at which cooling is required.

In Europe, the SEER is calculated based on criteria outlined in EN14825:2016

$$\text{SEER} = \frac{\text{total output cooling energy per season (kWh)}}{\text{total input electrical energy per season (kWh)}}$$

E

APPENDIX E



---

## APPENDIX E - DATA SOURCES USED TO DETERMINE EFFICIENCIES

Three main data sources were used to determine a realistic range of COPs and SCOPs:

1. **Field trials** – these usually calculate a combined Seasonal Performance Factor for a defined SEP/EMO-Build system boundary. In principle, these studies should provide reliable real-world performance data on heat pumps. In practice, heat pumps can be difficult to accurately monitor across dozens or even hundreds of test sites. Key variables such as distribution flow temperature can have a significant affect on efficiency and must be clearly accounted for. The complexity and nuance associated with these projects is easily masked by ‘average’ SPF values, which may be unfairly distorted by anomalous results. Generally, these studies have shown that heat pumps can operate very efficiently when properly designed and installed, but also much less efficiently if this is not the case.
2. **Public authority decisions** – these provide conservative ‘default’ values that are usually based on research reports and field trials. They can be vulnerable to technical bias, questionable assumptions and poor quality data (as previously described for field trials), which can invalidate these figures.
3. **Manufacturer test data** – these values provide a somewhat useful means of comparison between products, particularly within a given manufacturers range. It should be assumed that heat pumps submitted for testing are highly optimised to perform well under test conditions though. These conditions may not accurately represent real-world conditions. For example, a key limitation of EN14825:2016 is that it does not account for domestic hot water heating. Therefore, the results of testing under this standard are more likely to be accurate for air-air heat pumps or the space heating performance of air-water and ground-water systems.

F

A P P E N D I X F



## APPENDIX F - MAIN METHODS TO GENERATE HOT WATER IN BUILDINGS

A comparison of the main methods used to generate hot water in buildings is shown below along with the main advantages and disadvantages.

	PROS	CONS
<b>Gas boilers</b>	<ul style="list-style-type: none"> <li>• The most widely used of technologies</li> <li>• Provides space heating too</li> <li>• Relatively low capital and maintenance costs</li> <li>• Can generate large quantities of high temperature hot water (&gt;65-70°C) easily</li> <li>• Easy to modulate heat output and couples well with thermal storage</li> <li>• No refrigerants</li> </ul>	<ul style="list-style-type: none"> <li>• Requires a flue to expel waste gases and can impact local air quality</li> <li>• Carbon emissions are fixed with limited ability to reduce them in the future</li> <li>• Gas safety issues and testing</li> </ul>
<b>Direct electric / electric immersion heaters</b>	<ul style="list-style-type: none"> <li>• Widely used technology</li> <li>• Low capital and maintenance costs</li> <li>• Can generate high temperature hot water (&gt;65-70°C) easily</li> <li>• Easy to modulate heat output and couples well with thermal storage</li> <li>• No flue required or any impact on local air quality</li> <li>• Local point-of-use heaters eliminate distribution losses</li> <li>• Can be low carbon if it has a low carbon electricity source</li> <li>• No refrigerants</li> </ul>	<ul style="list-style-type: none"> <li>• Running costs</li> <li>• Carbon dioxide emissions are generally higher than gas boilers, when using electricity that has a carbon emissions factor greater than gas</li> <li>• When implemented at scale, likely to have a substantial impact on electrical infrastructure. This would greatly increase peak electrical demand at times when people are the most likely to use hot water (even with storage).</li> </ul>
<b>Air source heat pumps (electric)</b>	<ul style="list-style-type: none"> <li>• Can provide space heating</li> <li>• No flue or impact on local air quality</li> <li>• Generates heat more efficiently compared to direct electric</li> <li>• Carbon emissions will continue to decrease as grid emission factor reduces in the future</li> <li>• Eligible for RHI</li> </ul>	<ul style="list-style-type: none"> <li>• Higher capital costs compared to gas boilers or direct electric</li> <li>• Limited support and maintenance</li> <li>• Difficult to generate high temperatures efficiently, especially when outside air temperatures are low</li> <li>• Generally, only able to generate high enough temperatures for hot water when at an individual dwelling scale.</li> <li>• Requires outdoor units to be sited with pipework routed to indoor units (with the exception of internal ducted or exhaust air heat pump units)</li> <li>• Requires refrigerants to be used, which can be environmentally hazardous, toxic or flammable (or a combination of the above)</li> <li>• Noise</li> </ul>
<b>Ground source heat pumps</b>	<ul style="list-style-type: none"> <li>• Higher seasonal efficiency compared to air source heat pumps due to ground temperatures being more stable compared to the air</li> <li>• Can provide space heating</li> <li>• Does not require any outdoor units to be sited</li> <li>• Potential low maintenance costs / requirements</li> </ul>	<ul style="list-style-type: none"> <li>• High capital costs, especially where boreholes are required</li> <li>• Limited support and maintenance</li> <li>• Can be difficult to generate high temperatures for hot water efficiently</li> </ul>



	<ul style="list-style-type: none"> <li>• Generates heat more efficiently compared to direct electric</li> <li>• Carbon emissions will continue to decrease as grid emission factor reduces in the future</li> <li>• Can be used on a very large building or district energy centre scale</li> <li>• Eligible for RHI</li> <li>• No external noise outbreak</li> </ul>	<ul style="list-style-type: none"> <li>• Requires refrigerants to be used, which can be environmentally hazardous, toxic or flammable (or a combination of the above)</li> <li>• Can cause localised freezing of the ground</li> </ul>
<b>Combined Heat and Power (CHP)</b>	<ul style="list-style-type: none"> <li>• Can generate large quantities of high temperature hot water (&gt;65-70°C) easily</li> <li>• Can provide space heating</li> <li>• Does not require any outdoor units to be sited</li> <li>• Can be used on a very large building or district energy centre scale</li> <li>• No refrigerants</li> </ul>	<ul style="list-style-type: none"> <li>• High maintenance costs</li> <li>• Requires a large flue to be sited (at the highest point), and high NOx emissions can impact local air quality</li> <li>• No longer provides CO<sub>2</sub> emissions savings when using up-to-date grid electricity carbon emission factors</li> <li>• Requires a large amount of plant space and thermal storage</li> <li>• Does not modulate heat output well</li> <li>• Overall carbon savings will diminish as the grid's carbon emissions factor reduces</li> <li>• Requires a lot of air. Façade implications.</li> <li>• Noise</li> </ul>
<b>Biomass boilers</b>	<ul style="list-style-type: none"> <li>• Can generate large quantities of high temperature hot water (&gt;65-70°C) easily</li> <li>• Can provide space heating</li> <li>• Does not require any outdoor units to be sited</li> <li>• May provide significant carbon savings for buildings that have a large heating / hot water demand (at least on paper)</li> <li>• Can be used on a very large building or district energy centre scale</li> <li>• No refrigerants</li> <li>• Eligible for RHI</li> </ul>	<ul style="list-style-type: none"> <li>• High capital and maintenance costs</li> <li>• Requires a large flue to be sited (at the highest point), and high NOx and particulate emissions can impact local air quality</li> <li>• Requires a large amount of plant space for the boiler, fuel storage / feeding and thermal storage</li> <li>• Requires fuel deliveries and substantial storage</li> <li>• Does not modulate heat output well</li> <li>• Actual carbon savings may be greater than those calculated due to questions around how wood fuel carbon emissions factors are calculated</li> </ul>

Table App F.01– Advantages and disadvantages of different approaches to hot water generation

G

APPENDIX G



## APPENDIX G - THE UNCERTAINTIES ASSOCIATED WITH USING 302 GCO<sub>2</sub>/KWH FOR THE ELECTRICITY CARBON FACTOR

One consequence of performing carbon calculations for new developments using the 2019 marginal grid emissions factor of 302gCO<sub>2</sub>/kWh is that future emissions reductions that will occur during the lifetime of the heating system are not captured. In the calculation. Figures App G-01 and App G-02 demonstrate this, by comparing the carbon factor of heat based on forecast marginal emissions factors with the fixed marginal emission factor of 302. This results in underestimating the emissions from gas-fired CHP based heating systems by around 28% and overestimating the emissions from heat pump based heating systems by 40%.

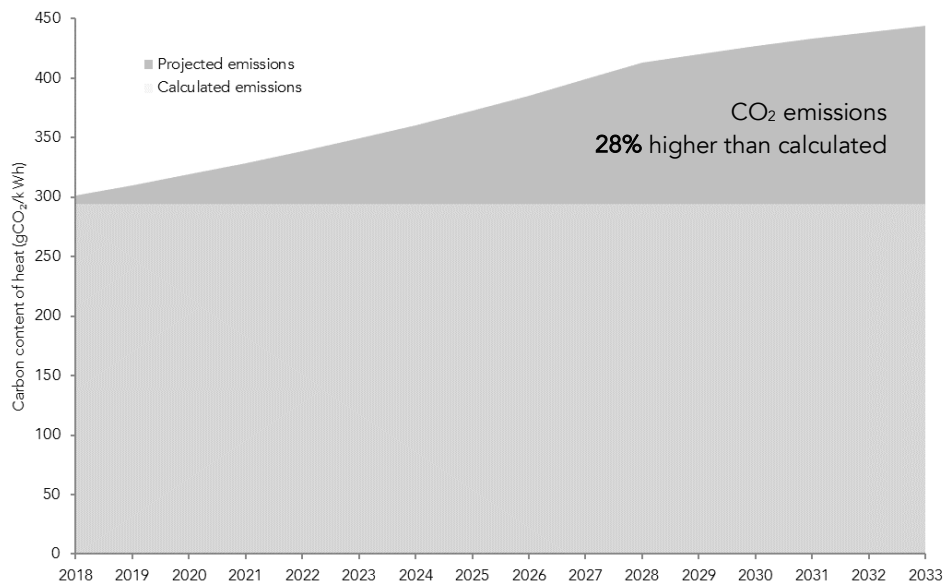

Figure App G.01 – Difference in carbon factor of heat between 2019 marginal grid emission factor and HM Treasury Green Book projections for a 70% gas fired CHP / 30% gas boiler district heating system

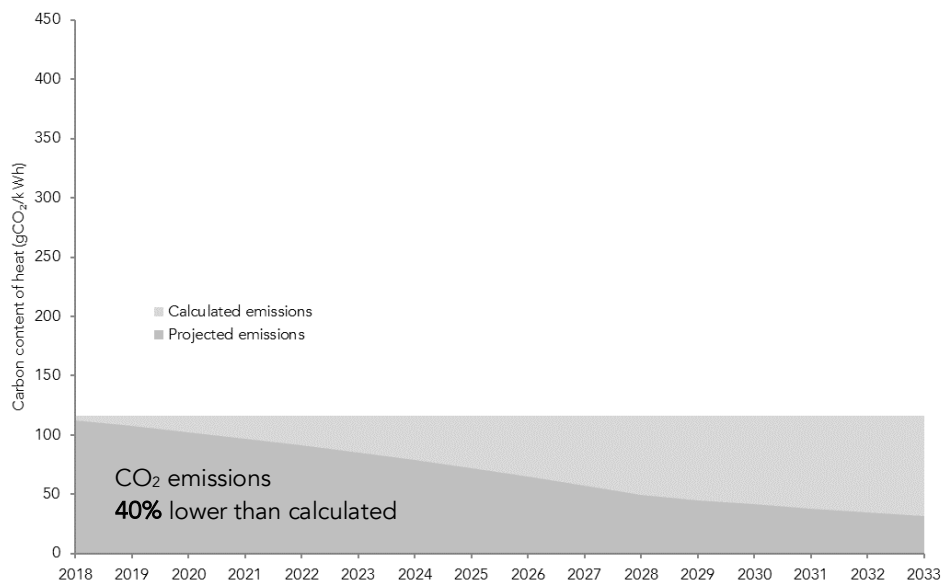

Figure App G.02 – Difference in carbon factor of heat between 2019 marginal grid emission factor and HM Treasury Green Book projections for a typical air source heat pump with an efficiency of 260%

H

A P P E N D I X H



---

## APPENDIX H - LITERATURE REVIEW

### FIELD TRIALS

A number of heat pump field trials were carried out in the UK to investigate their real-life performance.

***EST Heat pump field trials (Energy Saving Trust, 2013)***

The Energy Saving Trust (EST) study analysed performance of domestic air and ground source heat pumps monitored between 2008 and 2013. There were 2 phases: Phase 1 included 83 sites and Phase 2 is a follow up study of 44 sites which focused on improving the efficiency of poorly performing Phase 1 heat pumps through interventions.

***Preliminary data from the RHPP heat pump metering programme (DECC, 2014)***

Initial report of metering data from RHPP (400 heat pumps), analysing performance in SPF, EU renewable energy threshold (SPF<sub>H2</sub>) and carbon and cost savings.

***Renewable Heat Premium Payment Scheme study (University College of London for DECC, 2017)***

The study analysed data collected from domestic RHPP schemes, which includes 400 air and ground heat pumps.

***Non-domestic Renewable Heat Incentive study (Graham Energy Management for BEIS, 2018)***

Data from 28 ground and water source heat pumps installed under the non-domestic RHI schemes were analysed.

### OTHER REPORTS ON HEAT PUMPS

***Heat pumps in district heating (Element Energy for DECC, 2017)***

Report on how heat pumps can be integrated into district heating, including case and simulation results of different scenarios.

***Low carbon heating and the Renewable Heat Incentive (National Audit Office for BEIS, 2018)***

A report assessing the effect of the RHI in terms of carbon targets, costs and compliance.

***Renewable heat in Scotland, 2015 (Energy Saving Trust for Scottish Government, 2016)***

Summary of progress based on data from renewable heat sources in Scotland.

***Heat pumps in smart grids (Delta Energy & Environment for DECC, 2018)***

A series of report including to examine how to shift peak demand with heat pumps and provide DSR (demand side response).

***Monitoring of exhaust air heat pumps with underfloor heating (Kiwa for DECC, 2012)***

Monitoring of energy demand in 2 social housing flats equipped with exhaust air source heat pumps

***Low carbon heat tech domestic high temperature heat pump (BEIS, 2016)***

Report focusing on high temperature heat pumps, with analysis of performance based on existing products (modelling), and review of related market and standards.

***Interaction between hot water cylinders, buffer tanks and heat pumps (Kiwa for DECC, 2013)***

Based on EST field trials, examines losses from heat pump domestic hot water (DHW) cylinder in different operating modes and buffer tank optimisation.

***Effects of cycling on heat pump performance (EA technology for DECC, 2012)***

Based on tests ran on ASHP installed in an unoccupied house with standard radiator system (as an add-on to EST field trials), the report examines use of radiator valves (TRVs) and resultant effect on heat pump cycling. Tests were extended to include GSHP.

***Effect of installation and maintenance on heat pump performance (National Energy Foundation for DECC, 2013)***

Literature review of current standards and legislations in the UK heat pump industry also including: documented problems, heat pump controls, and end user advise.

# A P P E N D I X I



## APPENDIX I - WHO RESPONDED TO THE SURVEYS?

### General statistics

When asked about their level of expertise in heat pumps the distribution of responses were as follows:

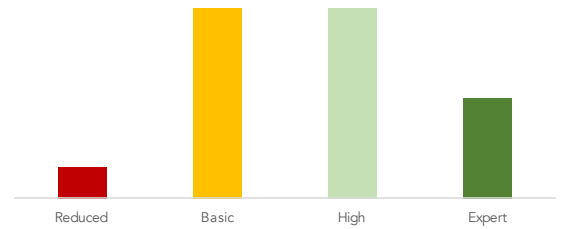

More than 80% of all respondents have experience in small- and medium-scale heat pumps but this proportion is more reduced for large scale heat pumps (i.e. 55%).

### Suppliers and installers

6 suppliers and distributors have responded including Daikin, Mitsubishi, Kensa, Vaillant, Glen Dimplex and Freedom Heat Pumps.

5 of the companies who responded also manufacture heat pumps. None of them install them and only 1 of them maintains them.

6 installers have responded. The heat pump brands being installed also include Samsung, NIBE, Viessmann, Ochsner, Stiebel-Eltron.

Suppliers, distributors and installers deal with all scales of heat pumps except for two respondents which do not deal with large scale heat pumps.

### Building industry professionals (incl. LETI participants)

The majority of respondents in this category are energy / sustainability consultants with mechanical engineers, contractors and developers also represented.

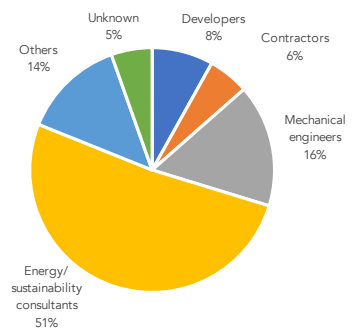

Only 1 architect responded to the questionnaire which could be related to the technical nature of the survey. This means that the view from architects, which is very important, is under-represented.

When asked about their type of involvement with heat pumps, the main responses were:

- I assess heat pump systems (e.g. in planning energy statements) – 54%
- I design heating systems – 46%
- I research heating system performance – 27%.

Respondents could provide more than one answer.

80% of respondents advise on the decision to use heat pumps or not in new buildings.



**Mechanical and Electrical engineers**

The number of response to the questionnaire addressed specifically to Mechanical and Electrical engineers with a particular focus on the impact of heat pumps on the electricity grid was relatively limited. Most respondents work on the design of heating systems with approximately 25% of them involved in the design of electrical systems.

One respondent in this category is Element Energy who have undertaken a number of studies on the long term impact of heat pumps on the electricity grid.

**Clients and housing associations**

Experience of heat pumps is limited across the (small) sample of clients and housing associations surveyed. None of the respondents have experience with large scale heat pump systems. Only one respondent has experience of a heat pump system in an apartment building.

**London boroughs – Energy and sustainability officers**

Energy officers have experience of projects at all scales and in all types of buildings but it is more limited for large scale heat pumps and in education buildings (e.g. schools).

J

A P P E N D I X J



## APPENDIX J HIGH LEVEL CAPITAL COST STUDY FOR A TYPICAL MEDIUM DENSITY APARTMENT BLOCK

A medium-density apartment building of 85 units was considered (50% affordable 50% private) with a total floor area of 7,360 m<sup>2</sup> GIA. This case study can be considered comparable to the 'single residential block' used by Buro Happold in their report 'The future role of the London Plan in the delivery of area-wide district heating'. Although they have based their analysis on twice the number of units, we would expect the results to be broadly similar on a per unit basis. It is assumed that the building represents current practice in London for similar schemes with:

- Fabric performance in line with 'good practice': e.g. external wall U-value of 0.13 W/m<sup>2</sup>.K, window U-value of 1.3 W/m<sup>2</sup>.K, airtightness of 3 m<sup>3</sup>/h/m<sup>2</sup> at 50 Pa)
- Mechanical Ventilation with Heat Recovery (MVHR) in all units
- Connection (to the edge of the site) to a District Heating system supplied by gas-fired boilers and CHP
- A small area of PVs in order to achieve the required 35% improvement over Part L 2013
- Carbon offsetting to reduce the regulated carbon emissions to zero through a s106 contribution.

### Baseline costs

A baseline construction cost of £21,050,000 (based on a similar scale project) and the following have been assumed:

- Construction costs are based on current costs and therefore inflation is excluded;
- Professional fees and planning fees are not included;
- M&E preliminaries have been assumed at 11% of the M&E costs;
- Main contract preliminaries have been assumed at 16% of the construction costs;
- Main contract overheads and profits have been assumed at 5% of the construction costs;
- Contingencies have been assumed at 5% of the construction costs;
- The costs includes a carbon offsetting contribution based on £95/tonne CO<sub>2</sub>.

### Detailed assumptions used for costs analysis – System description

Scenario	Description	ASSUMPTIONS					
		Infrastructure	Communal plant	Distribution	Heat interface	Heat emitters	DHW
Baseline	<b>Connection to District Heating Network with CHP</b>	Pre-insulated pipework mains to edge of the site	<b>360kW Heat substation</b> (packaged plate heat exchanger). Expansion vessels, secondary distribution pumps, pressurisation unit.	LTHW mains to each unit 2 pipe flow and return configuration	<b>Hydraulic interface unit</b> (heating and domestic hot water)	Radiators or LTHW underfloor heating	Instantaneous from main heating system ( <b>via HIU</b> )
Ref 1	Communal gas boilers	Incoming gas main	<b>4 x 120kW Modular (cascading) gas boilers.</b> Direct flues. Gas meter room. Buffer vessels, expansion vessels, circulation pumps, headers, pressurisation unit	LTHW mains to each unit 2 pipe flow and return configuration	<b>Hydraulic interface unit</b> (heating and domestic hot water)	Radiators or LTHW underfloor heating	Instantaneous from main heating system ( <b>via HIU</b> )
Ref 2	Direct electric heating	-	<b>Increased capacity local substation.</b>	Increased cable trays to each apartment.	<b>Hot water cylinder in each apartment</b>	Direct electric panel radiators or electric underfloor heating	<b>Individual hot water cylinder</b> with immersion heater
HP 1	<b>Building level air source heat pump system with water distribution to HIUs</b>	-	<b>9 x 40kW modular external air-to-water HP units</b> located on the roof with acoustic screening. Internal plant room with central DHW calorifiers. Expansion vessels, circulation pumps, pressurisation unit.	LTHW mains to each unit 2 pipe flow and return configuration	<b>Hydraulic interface unit</b> (heating and domestic hot water)	Radiators or LTHW underfloor heating	<b>Communal indirect DHW tank</b> with LTHW from HIU and immersion heater for temperature boost
HP 2	<b>Building level air source heat pump system with refrigerant distribution to FCUs and separate system for DHW</b>	-	<b>3 x 80kW modular external ASHP units for heating and 2no 40 kW modular external ASHP units for DHW</b> located on the roof with acoustic screening. Internal plant room with central DHW calorifiers. Expansion vessels, circulation pumps, pressurisation unit.	Refrigerant pipework to Hybrid Branch Controllers Water pipes from Hybrid Branch Controllers to fan-coil units DHW pipes	2-3 x <b>Hybrid Branch Controllers</b> per floor in Landlord's area (including leak detection) <b>and hot water cylinder in each apartment</b>	Floor standing fan-coil units with metered connections from Hybrid Branch Controllers	<b>Communal indirect DHW tank</b> with metered connection from central calorifier system and immersion heater for temperature boost
HP 3	<b>Communal ground loop with individual heat pumps</b>	Ground array (20 x boreholes, 200m deep)	<b>None</b> (each individual GSHP is equipped with circulation pump)	Ground water flow and return - 2 pipe flow and return configuration	<b>Individual heat pump and hot water cylinder in each apartment</b>	Radiators or LTHW underfloor heating	<b>Indirect individual hot water cylinder</b> with LTHW from HP and immersion heater for temperature boost
HP 4	<b>Connection to Waste Heat Network with building level heat pump system</b>	Pre-insulated water loop to edge of the site	<b>6 x 60kW water-to-water heat pumps in communal plant room.</b> & buffer vessel. Expansion vessels, circulation pumps, pressurisation unit.	LTHW mains to each unit 2 pipe flow and return configuration	<b>Hydraulic interface unit</b> (heating only with DHW cylinder)	Radiators or LTHW underfloor heating	<b>Indirect individual hot water cylinder</b> with LTHW from HIU and immersion heater for temperature boost

Table App J.01 – Overview of key assumptions

K

APPENDIX K



## APPENDIX K HIGH-LEVEL REVIEW OF HEATING COSTS FOR RESIDENTS

A comprehensive analysis of cost reports and studies has been done to inform the heating cost assessment. Documents used in this assessment are summarised in the table on the following page.

The table below summarises the key assumptions made for each system against each key category below.

System	Fuel costs	Maintenance cost/charge	Replacement cost/charge	Metering/billing charge	Other charges
Individual gas boiler	3.6p/kWh for gas	£150/year	Equivalent annual cost of £113/year based on £1,860 and 11.2 years lifespan	N/A	N/A
Direct electric	14.4p/kWh for electricity	£50/year	Equivalent annual cost of £26/year based on £500 and 30 years lifespan (replacement of cylinder after 20 years)	N/A	N/A
Individual ASHP	14.4p/kWh for electricity	£200/year	Equivalent annual cost of £190/year based on £3,000 and 12.5 years lifespan (replacement of cylinder after 20 years)	N/A	N/A
Communal gas boiler	3.6p/kWh for gas	£120/year (including HIU)	£90/year (sinking fund)	£125/year	N/A
Communal ASHP	14.4p/kWh for electricity	£140/year (including HIU)	£110/year (sinking fund)	£125/year	N/A
Communal ground loop, individual HP in each unit	14.4p/kWh for electricity	£150/year	Equivalent annual cost of £150/year based on £3,500 and 17.5 years lifespan (replacement of cylinder after 20 years)	£20/year	N/A
District heating (gas boiler + CHP)	2.2p/kWh for gas 5p/kWh for electricity export	£110/year	£90/year (sinking fund)	£110/year	£100/year
District heating (gas boiler + high temperature HP)	5.7p/kWh for electricity	£110/year	£110/year (sinking fund)	£110/year	£100/year

Table App K.01 – Overview of key assumptions

The table below summarises the key source(s) of information used for these assumptions. Please note that in some instances project experience from Etude has been used directly or to correct a figure which seemed disproportionate.

System	Fuel costs	Maintenance cost/charge	Replacement cost/charge	Metering/billing charge	Other charges
Individual gas boiler	BEIS annual statistics for 2017	Which? 2015 <sup>2</sup> DECC 2015 <sup>1</sup>	Which? 2015 <sup>2</sup> DECC 2015 <sup>1</sup>	N/A	N/A
Direct electric	BEIS annual statistics for 2017	Project experience	Project experience	N/A	N/A
Individual ASHP	BEIS annual statistics for 2017	BEIS (element) 2017 <sup>4</sup> Projects experience	BEIS (element) 2017 <sup>4</sup> Market data (i.e. Mitsubishi) Project experience	N/A	N/A
Communal gas boiler	BEIS annual statistics for 2017	Project experience	Which? 2015 <sup>2</sup> Project experience	NMRO guidelines <sup>5</sup> DECC 2015	N/A
Communal ASHP	BEIS annual statistics for 2017	BEIS (element) 2017 <sup>4</sup> Project experience	BEIS (element) 2017 <sup>4</sup> Market data (i.e. Misubishi) Project experience	NMRO guidelines <sup>5</sup> DECC 2015 <sup>1</sup>	N/A
Communal ground loop, individual GSHP	BEIS annual statistics for 2017	BEIS (element) 2017 <sup>4</sup> Project experience	BEIS (element) 2017 <sup>4</sup> Market data (i.e. Kensa)	Project experience	N/A
District heating (gas boiler + CHP)	Ofgem wholesale market prices for march, 2018	DECC 2015 <sup>1</sup> Project experience	DECC 2015 <sup>1</sup> Project experience	DECC 2015 <sup>1</sup> Which? 2015 <sup>2</sup>	DECC 2015 <sup>1</sup> Which? 2015 <sup>2</sup>
District heating (gas boiler + high temperature HP)	Ofgem wholesale market prices for march, 2018	DECC 2015 <sup>1</sup> DECC 2016 <sup>3</sup> Project experience	DECC 2015 <sup>1</sup> DECC 2016 <sup>3</sup> Project experience	DECC 2015 <sup>1</sup> Which? 2015 <sup>2</sup>	DECC 2015 <sup>1</sup> Which? 2015 <sup>2</sup>

Table App K-02 – Overview of key sources of information used for each assumption

<sup>1</sup>DECC 2015 - Assessment of the costs, performance, and characteristics of UK Heat network

<sup>2</sup>Which? 2015 - Turning up the heat

<sup>3</sup>DECC 2016 – Heat pumps in district heating

<sup>4</sup>BEIS (element) 2017 – Hybrid heat pumps final report

<sup>5</sup>NMRO guidelines – National Measurement & Regulation Office heat network metering and billing

**Results and analysis**

**Individual systems**

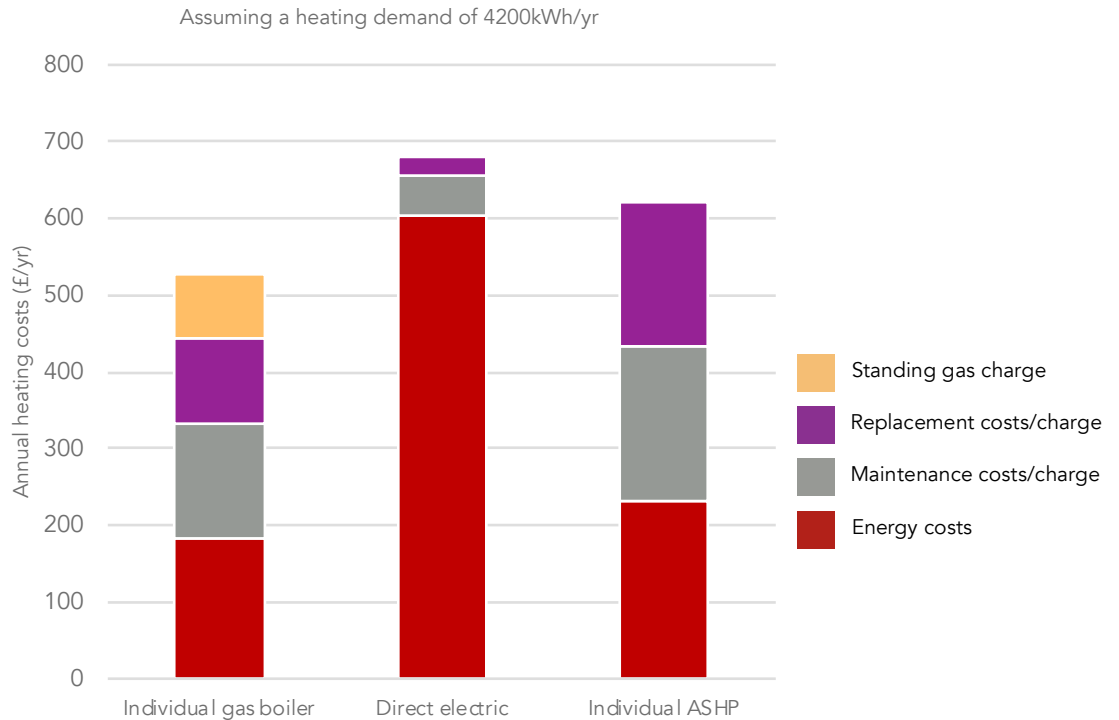

**Figure App K-01 - Comparison of predicted heating costs for the resident of a 2-bed energy efficient apartment**

Out of the individual heating systems above, the **individual gas boiler** appears to be the cheapest system to run currently given the relatively low price of gas compared with electricity and the relatively low maintenance and replacement costs compared with a heat pump system. Their heating costs represent, however, a useful reference point at approximately £520/yr for this particular case.

The **direct electric heating** system is another useful point of reference. As the 2-bedroom flat is relatively energy efficient, the total heating cost is less than £700/yr but is very sensitive to the energy demand. Maintenance and replacement costs are marginal and mainly associated with the hot water cylinder.

The **individual air source heat pump** system, due to its efficiency over direct electric, is less sensitive to the energy demand. As electricity is a more expensive form of energy than gas, the energy costs are still higher than the individual gas boiler reference though but much less than the direct electric scenario. However, maintenance costs and replacement costs make up a greater proportion of the total cost compared to the other systems and push the total heating costs over £600/yr. If these costs were to reduce over time due to improvements in the supply chain and economies of scale (which is likely), the total costs could reduce and become closer to the individual gas boiler scenario.



**Communal/building scale systems**

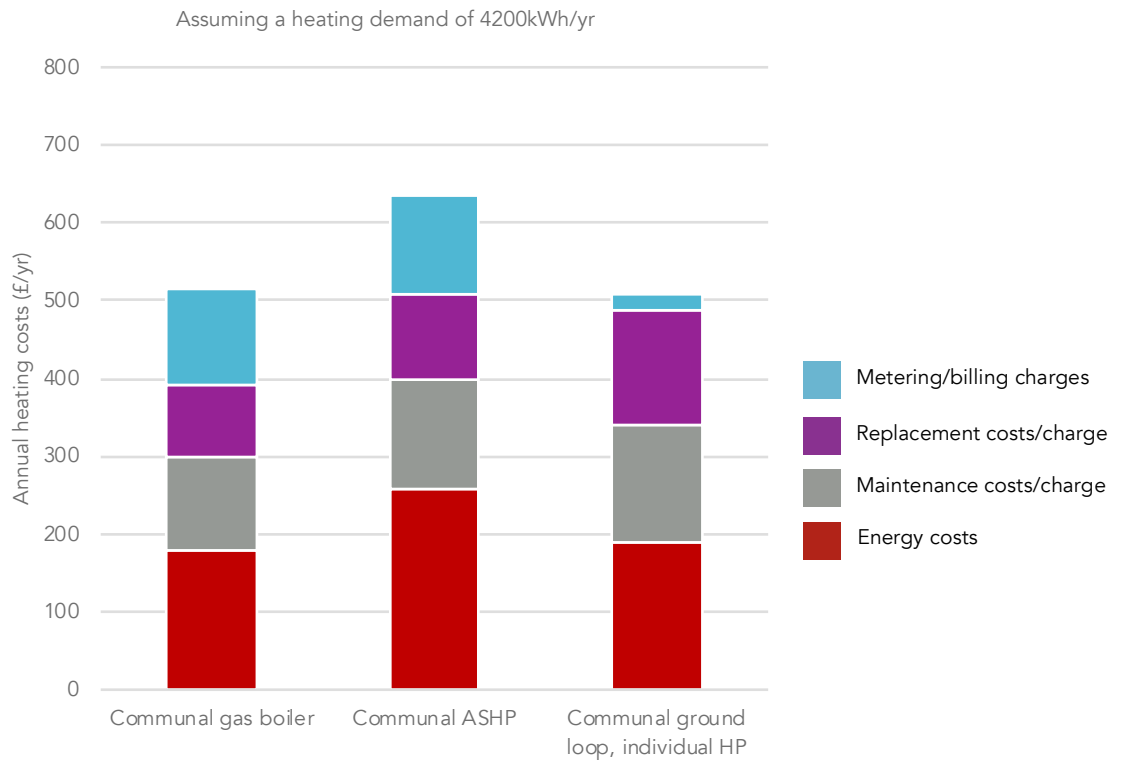

**Figure App K-02 - Comparison of predicted heating costs for the resident of a 2-bed energy efficient apartment**

Heating costs associated with the **communal gas boiler** scenario depends significantly on the scale of the communal system. This analysis assumes a relatively small scale and therefore a gas purchase price broadly comparable to residential prices. Any savings on that cost could be passed on to the residents. The analysis indicates that savings in maintenance and replacement costs could be offset by additional metering and billing charges and bring total heating costs to just over £500/yr. If the latter are kept to a minimum, this solution could become the most economical for the residents. However, as for the individual gas boiler, this solution is not as beneficial as the heat pump alternatives in terms of air quality and carbon emissions.

The **communal air source heat pump** system’s impact on heating costs relies on a similar dynamic: savings in maintenance and replacement costs compared to an individual system could be offset by additional metering and billing charges as the system assumed still relies on individual heat interface units and heat meters. Annual heating costs are estimated at just over £600/yr. However, this analysis assumes a relatively small scale system and therefore an electricity purchase price comparable to residential prices. If electricity could be purchased at a lower price (e.g. 30-35% less as is typical for larger customers) and savings passed on, annual heating costs could be brought towards £550/yr.

The **communal ground loop with individual heat pumps** appears to be the most economic solution of all (at approximately £500/yr) and is also compliant with London’s key objectives in terms of air quality and carbon emissions. It combines several advantages: it is very energy efficient and does not require dedicated heat metering and billing. However, it would require additional space compared to a system with heat interface units.

**District scale systems**

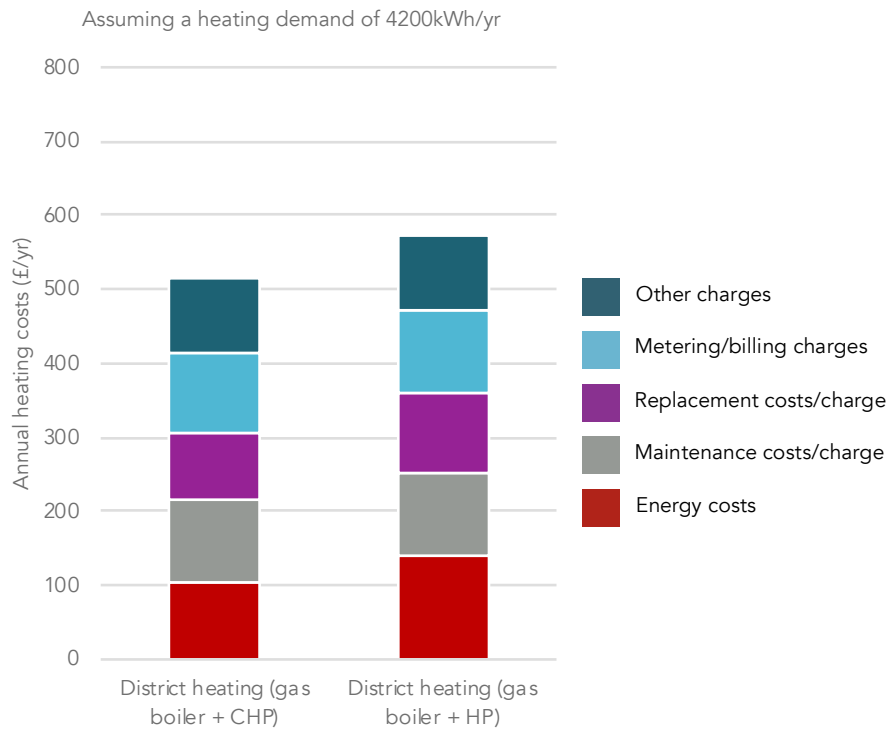

**Figure App K-03 - Comparison of predicted heating costs for the resident of a 2-bed energy efficient apartment**

Heating costs associated with district heating are very difficult to estimate as there is a significant number of systems and business models. Research also identifies a very significant variation in the cost of heat, by a factor of 1 to 3 (Source: Which? 2015 - Turning up the heat).

As a simplification we have assumed in the analysis above that residents would be charged an average rate of 12p/kWh in total (which represents a reasonable average) and we have attempted to break down what these costs would be made up of.

The **district heating with gas boilers and CHP** scenario has a very low energy cost component due to the low price of wholesale gas used in the energy centre and to the fact that the sale of electricity partially offsets these costs. Maintenance and replacement costs/charges are relatively low as they benefit from the large scale. Metering and billing charges can remain significant. Contrary to the other scales, there are also 'other charges' which may include a variety of costs: capital repayment for the plant, additional staff/resources for operation, additional overheads and profit. It is very difficult to estimate those charges but the analysis indicates that for the total costs to be competitive with an individual gas boiler scenario (i.e. heating costs of just over £500/yr) 'other charges' should be kept to approximately £100/yr for an average 2-bed apartment.

The main differences associated with the **district heating with gas boilers and air source heat pumps** is that the energy cost component does only benefit from the low prices of wholesale gas and electricity (and not from the sale of electricity as there is no CHP). Maintenance and replacement costs/charges are a little bit higher and similarly to the other district heating system scenario, the 'other charges' are critical to keep the overall heating costs under £600/yr.

**Summary**

The figure below summarises the total heating costs based on the analysis of the previous pages. An error bar has been added to each bar chart to indicate the approximate margin of error, which generally increases with the scale of the system given the variety of costs and systems available.

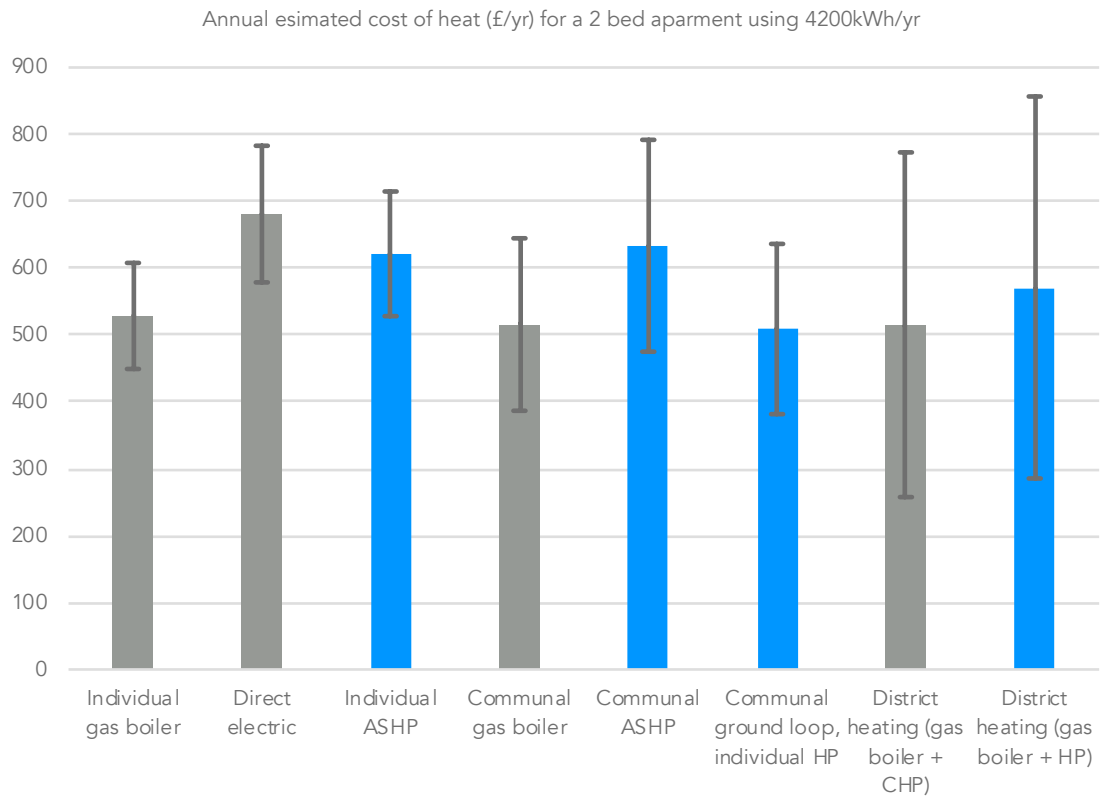

**Figure App K-04 - Comparison of predicted heating costs for the resident of a 2-bed energy efficient apartment**

The bar chart above indicates that typically heat pump solutions are likely to lead to a small increase in annual heating costs compared to the cheapest non-heat pump solution (communal gas boiler), however the communal ground loop with individual heat pumps is the cheapest overall as it is very efficient).

It is however important to note that:

1. The costs associated with a communal air source heat pump system ('Communal ASHP below') will be lower if electricity is purchased at a cheaper rate.
2. The costs of metering and billing are an important component of all communal and district scale systems and should low in order to help maintain low heating costs.
3. At the district scale, 'other charges' are an important component and our analysis suggests that they should be kept to a maximum of £100/year for an average 2-bed apartment in order for heating costs to remain competitive.

**Uncertainty**

The figure below illustrates the extent of uncertainty and impact on cost of heat between different systems and the impact it can have on the conclusions. For example, a communal air source heat pump solution could lead to heating costs equivalent to a communal gas boiler system if it is well designed, commissioned and maintained and if the electricity it uses can be purchased at a lower rate. On the other hand, an inefficient system relying on a standard cost of electricity could lead to heating cost equivalent to direct electric.

The important message expressed by the figure below is that it is not possible to establish a fixed hierarchy of heating costs by system. Instead, one can establish an indicative hierarchy and highlight the importance of design, installation, commissioning, maintenance and utility prices in order to reduce these heating costs as much as possible for the residents.

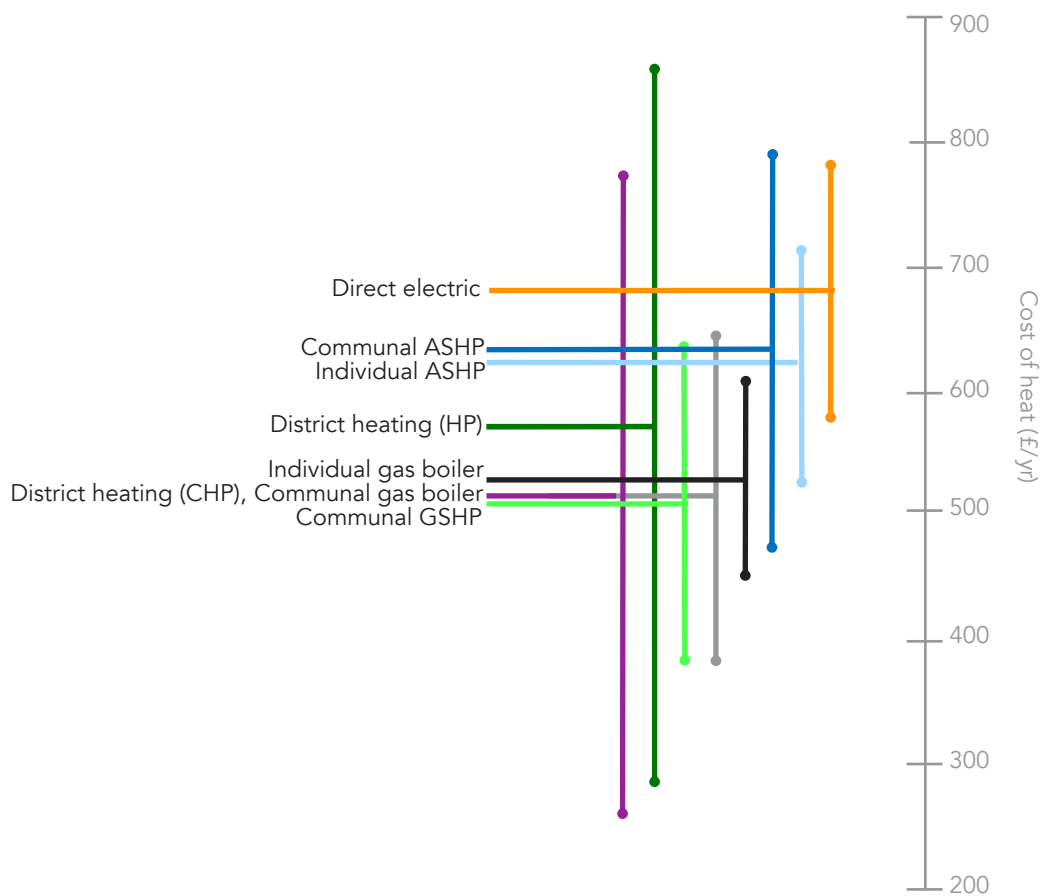
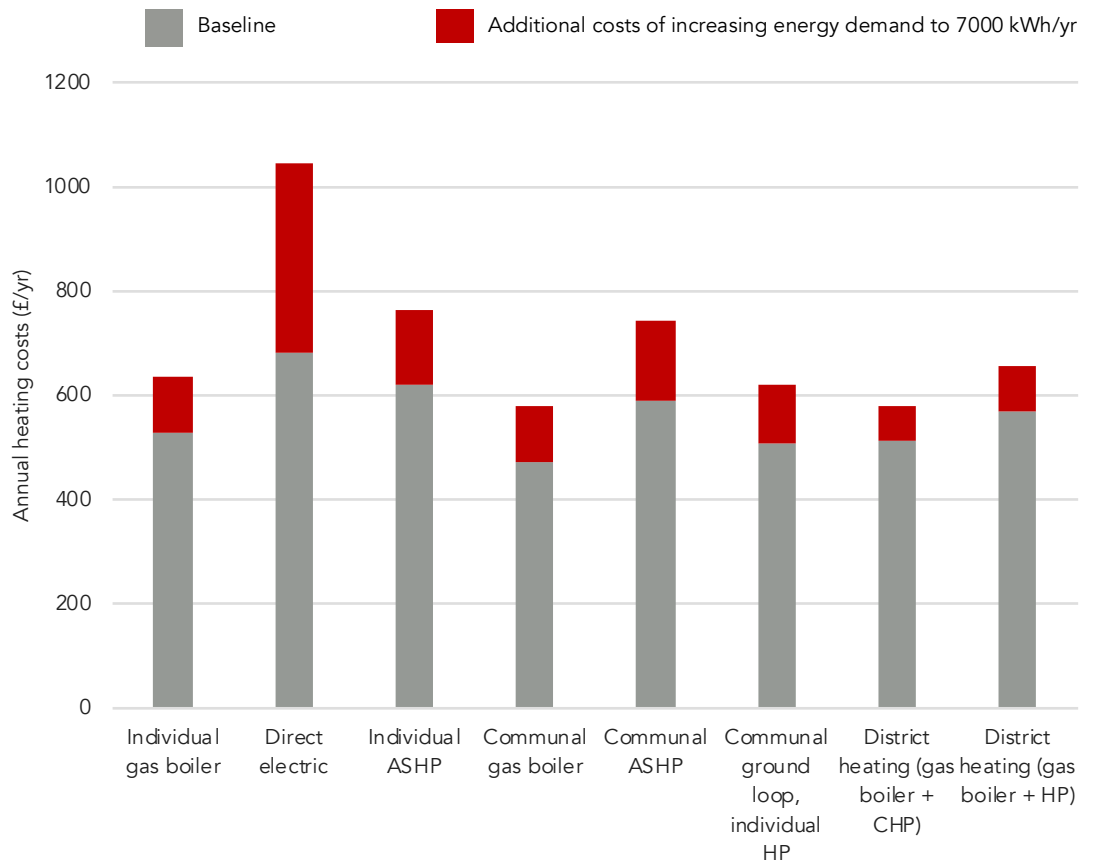

Figure App K-05 - Impact on error margins on the comparison of heating costs.

**Sensitivity analysis: What if...**

**What if the apartment is less efficient?**

The figure below represents the impact of an increased heating demand (e.g. 7,000 kWh rather than 4,200 kWh assumed in the baseline). This would be representative of an average 'poor construction quality' new build apartment.



**Figure App K-06 - Impact of increased energy demand on likely heating costs**

An increase in heating demand would negatively impact the direct electric systems' heating costs to a greater extent as electricity has a high unit cost. In this case the increased demand has almost a proportional effect and it adds more than 50% to the heating costs.

This effect is mitigated in heat pump based systems as the efficiencies of heat pumps mean the electricity required to meet the heating demand is significantly less.

District heating with CHP benefits from buying gas, which is a cheaper fuel than electricity at an even lower price at wholesale market rate, therefore is the least affected by an increase in heating demand.

**What if the apartment is more efficient?**

The figure below represents the impact of a reduced heating demand (e.g. 2,500 kWh rather than 4,200 kWh assumed in the baseline). This would be representative of a best practice 'high construction quality' new build apartment (e.g. built to the Passivhaus standard).

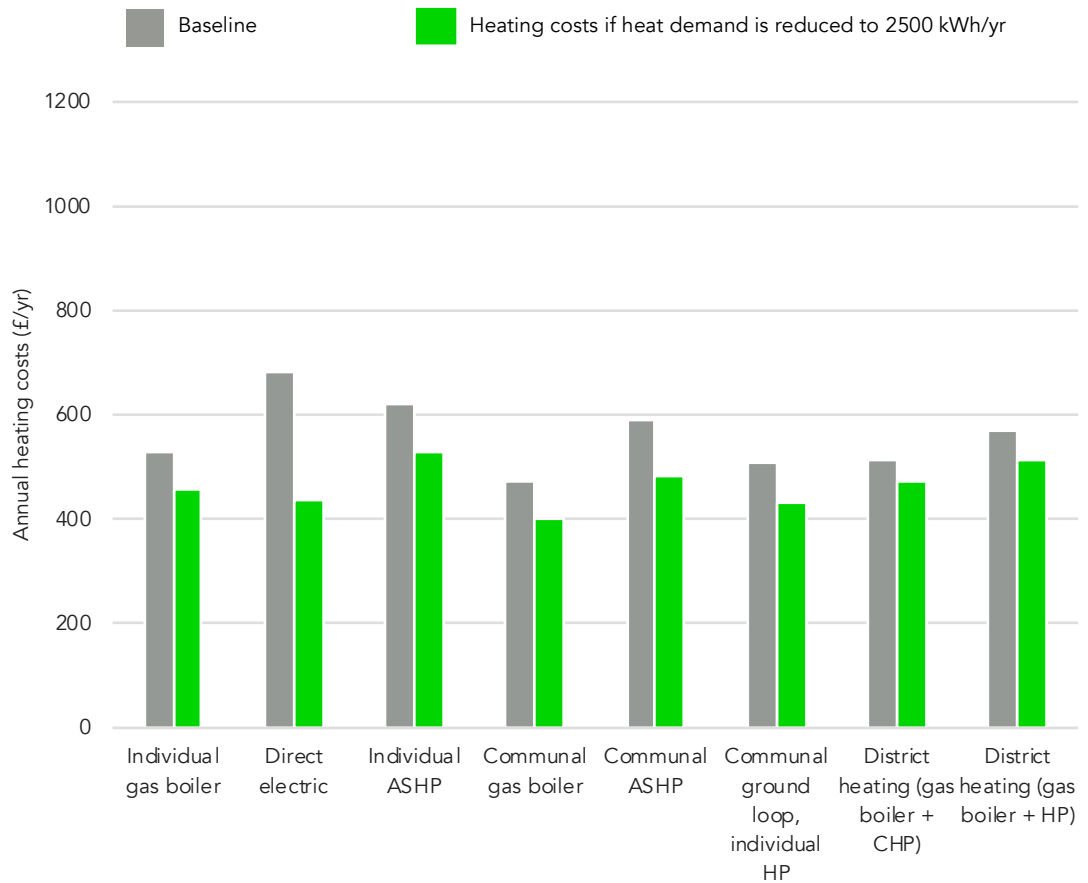

**Figure App K-07 - Impact of reduced energy demand on likely heating costs**

A reduction in heating demand to very low levels (equivalent to best practice / Passivhaus standards) would bring the estimated heating cost of all systems under £500/year except for the individual air source heat pump ('individual ASHP' above, for which the proportion of maintenance and replacement costs are still significant) and the district heating system with gas boilers and heat pumps.

Estimated heating costs for all systems would be less than £550/year though suggesting that high levels of energy efficiency are necessary to ensure that low carbon heat leads to affordable heating costs.

**What if the heat pumps is 20% less efficient than predicted?**

The figure below represents the impact of a reduced heat pump efficiency due to poor design/installation/commissioning.

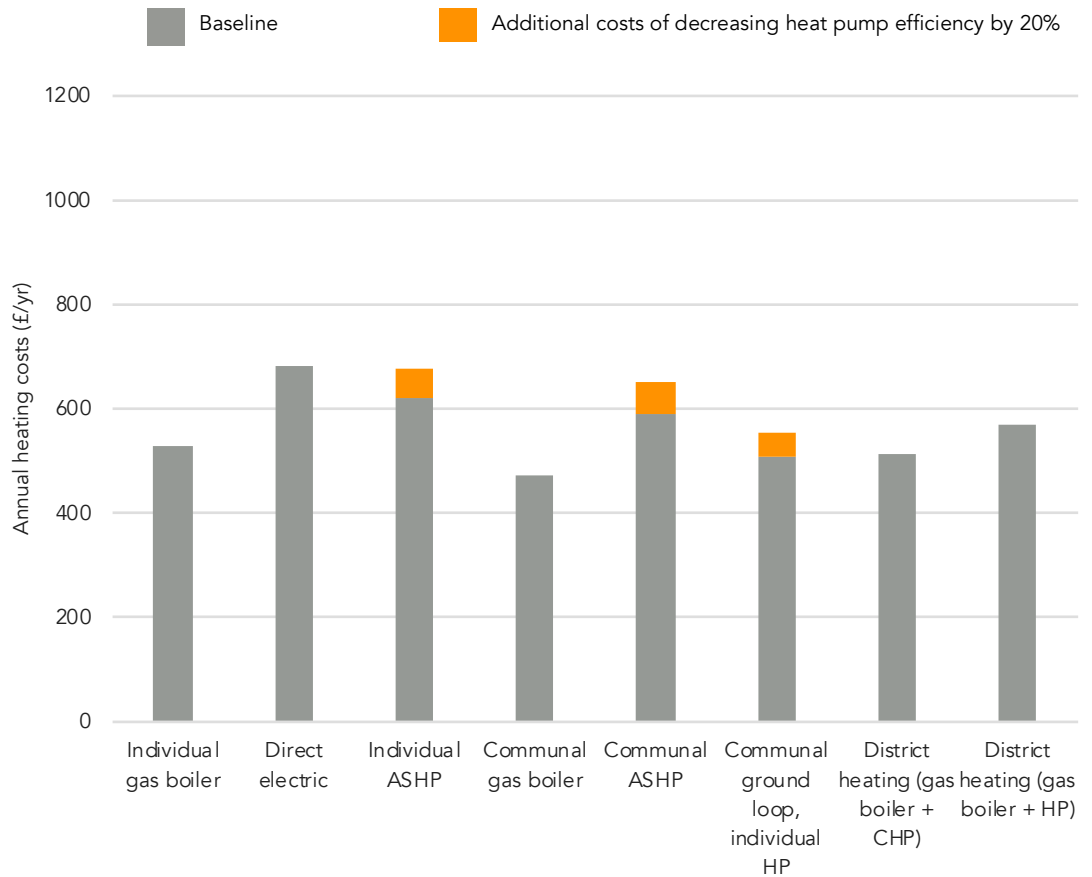

**Figure App K-08 - Impact of reduced heat pump efficiency on likely heating costs**

This analysis demonstrates how critical it is for the design, installation and commissioning of heat pump systems to be right. A relatively modest reduction in efficiency of 20% would push the heating costs of individual and communal heat pump system closer to the direct electric heating costs. A reduction in efficiency of 50% would have an even stronger effect.

The effect is more reduced on the communal ground loop with individual heat pump system and on the district scale system.

**What if gas and electricity prices rise significantly in the future?**

Historical rates of inflation for gas and electricity can provide useful context when trying to predict potential future trends. The long term average adjusted rates of inflation for gas and electricity between 1997 and 2014 were 6.5% and 3.7% respectively. However, as shown in the figure below, the prices of both have been relatively volatile.

Gas has played a steadily increasing role in UK electricity generation over the past few decades, supplying 30% of electricity generated in 2014, which explains to some extent why the price of electricity fluctuates in line with the price of gas.

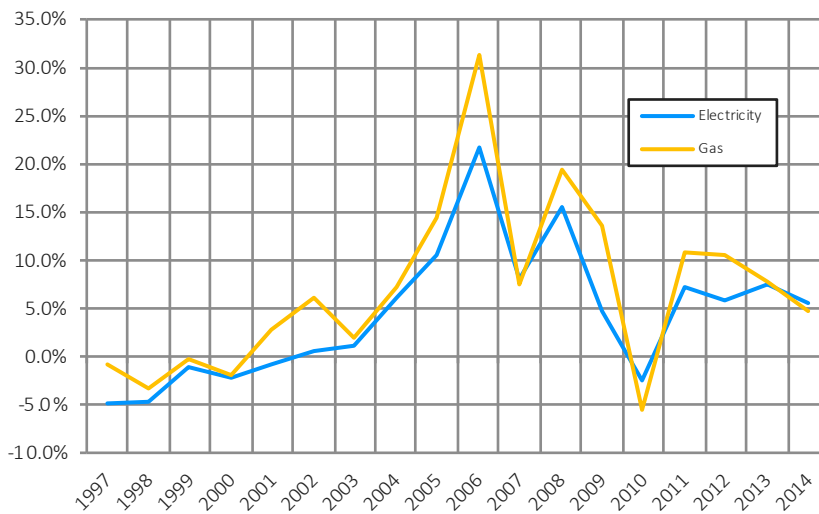

**Figure App K-09 - Unadjusted variation in domestic fuel price index (2010 base year) from DECC (2015) Quarterly Energy Prices**

The two main drivers behind the lower fluctuations in electricity price inflation relative to gas are:

- A greater percentage of the cost of electricity can be attributed to fixed costs associated with generation and delivery infrastructure, which has a stabilising effect on prices paid by end users.
- Electricity is generated from a mix of energy sources, and the costs associated with nuclear and renewable energy power plants in particular are less volatile than gas.

This trend towards more stable electricity prices is likely to continue in the future: even in the conservative National Grid 'no progression' scenario, it is assumed that gas will contribute just under 23% of annual electrical energy by 2035, reducing further the effect of the price of gas on electricity prices.

Forecasting future costs for gas and electricity is complex though and highly uncertain as there are a wide variety of factors that may influence costs. Examples include national and international trends in legislation, regulation and taxation of different energy sources, foreign conflicts and changing geopolitical motivations, and developments in supply and demand. We have therefore considered scenarios:

- An increase in utility prices (electricity and gas) of 30%, which historic data prove to be possible.
- An increase of gas prices only of 30%.
- An increase of electricity prices only of 30%.



**What if utility prices increase by 30%?**

The figure below represents the impact of an increase of all utility prices used in the baseline comparison by 30%.

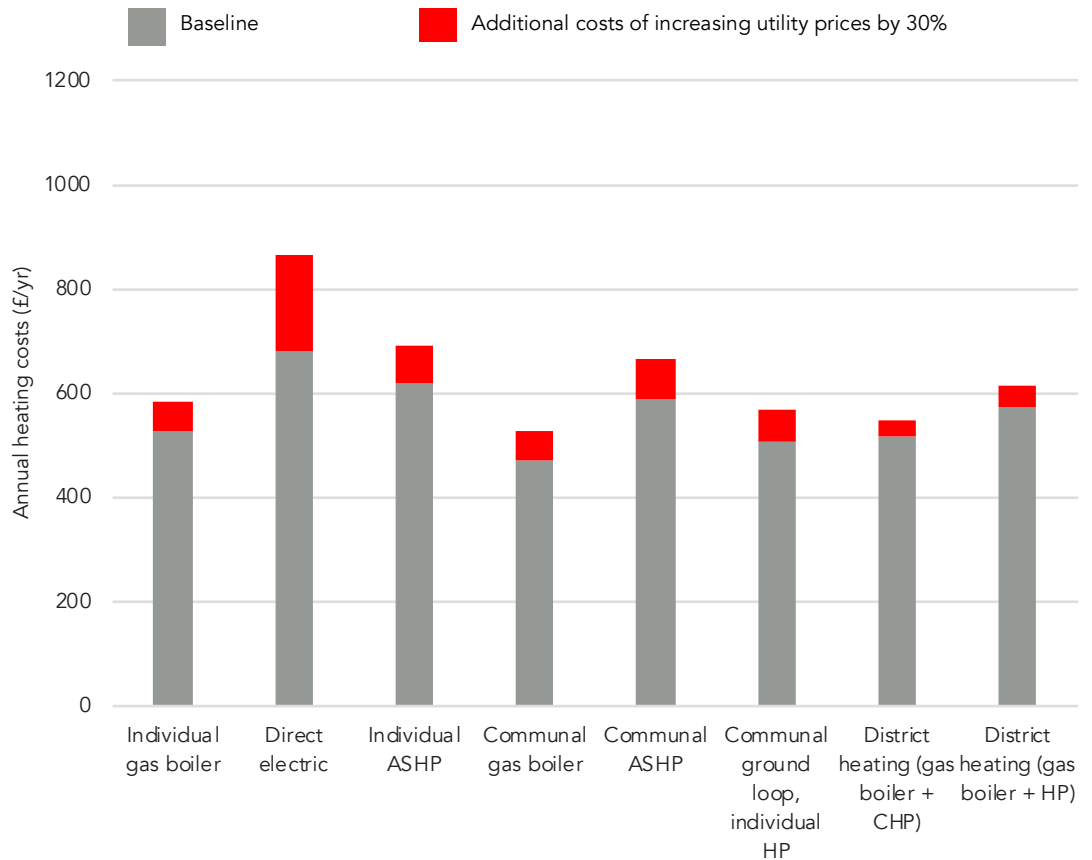

**Figure App K-10 - Impact of utility price increase on likely heating costs**

In summary:

- Electricity based systems will be more affected than gas-based systems as they use electricity as the main fuel (a 30% increase in electricity price will have a larger impact in absolute terms than a 30% increase in gas price);
- The effect on heating costs of direct electric systems will be most significant as the proportion of direct energy costs is much higher;
- The effect is reduced at a large scale when systems benefit from cheaper utility prices and therefore smaller increases in absolute terms.

**What if only gas prices increase by 30%?**

The figure below represents the impact of an increase of gas prices only by 30%.

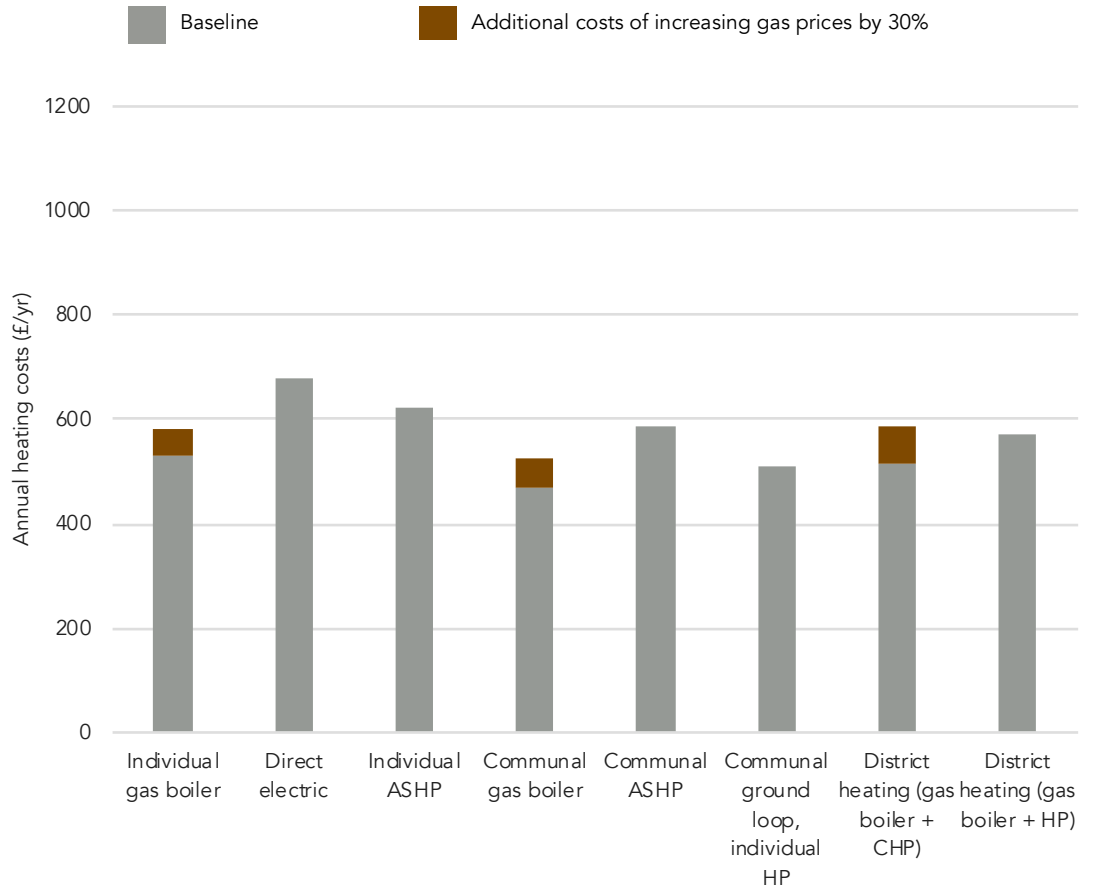
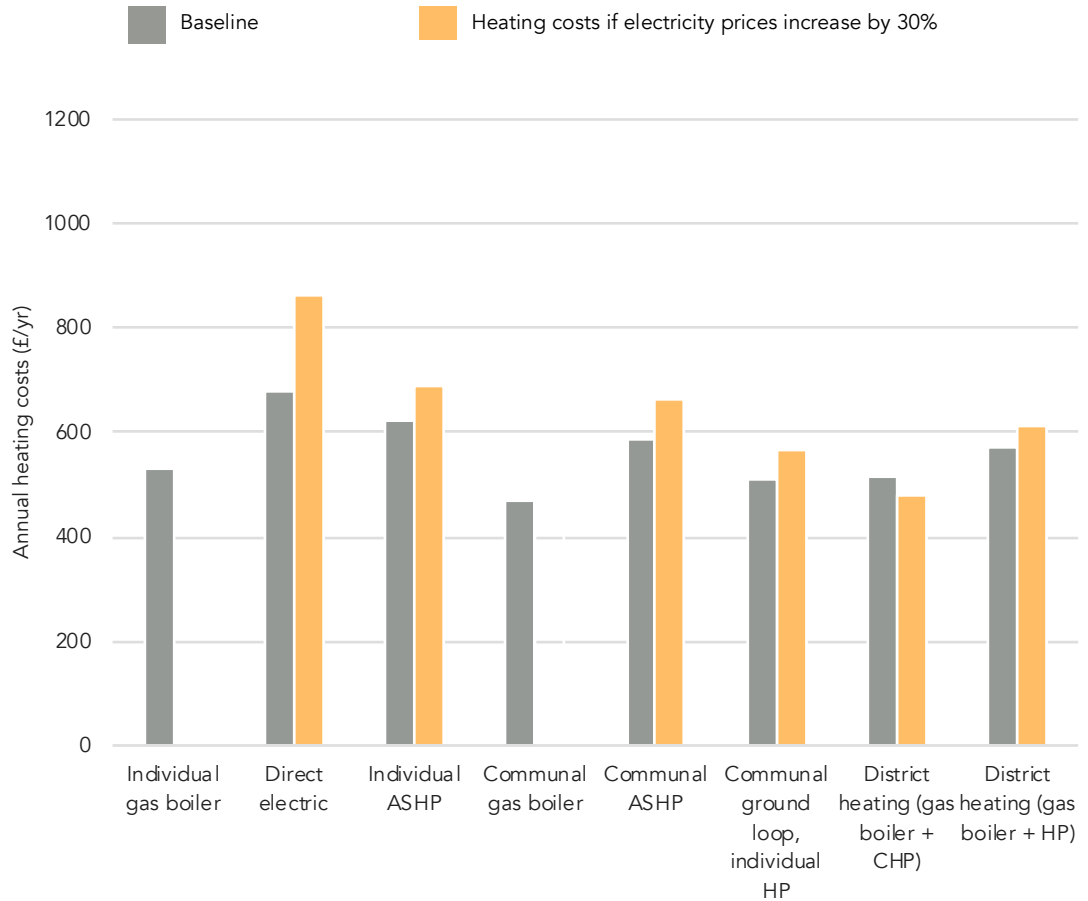

**Figure App K-11 - Impact of gas price increase on likely heating costs**

The effects of this change would be marginal as gas prices would still be relatively low compared with electricity prices.

**What if only electricity prices increase by 30%?**

The figure below represents the impact of an increase of electricity prices only by 30%.



**Figure App K-12 - Impact of electricity price increase on likely heating costs**

The effects of this change would be particularly significant for direct electric system which would be very exposed to the variability of electricity prices. On the other hand, district heating with gas-fired CHP would benefit from the increase in electricity prices through the sale of electricity generated by the CHP.

Heat pump systems would have higher heating costs but the most efficient systems (e.g. communal ground loop, waste heat source heat pump) would be less exposed than the air source systems.

**What if the replacement cost of heat pumps is 10% lower than assumed**

It is possible that the costs of heat pumps will decrease over the next 10-15 years as demand increases. The figure below indicates the impact that a modest decrease in replacement cost (i.e. 10%) would have on the estimated annualised heating costs. This is considered reasonable based on the 2016 DECC study into the potential cost reduction for heat pumps which indicates that a 10% reduction for equipment costs and a 40-50% reduction for non-equipment costs can be expected.

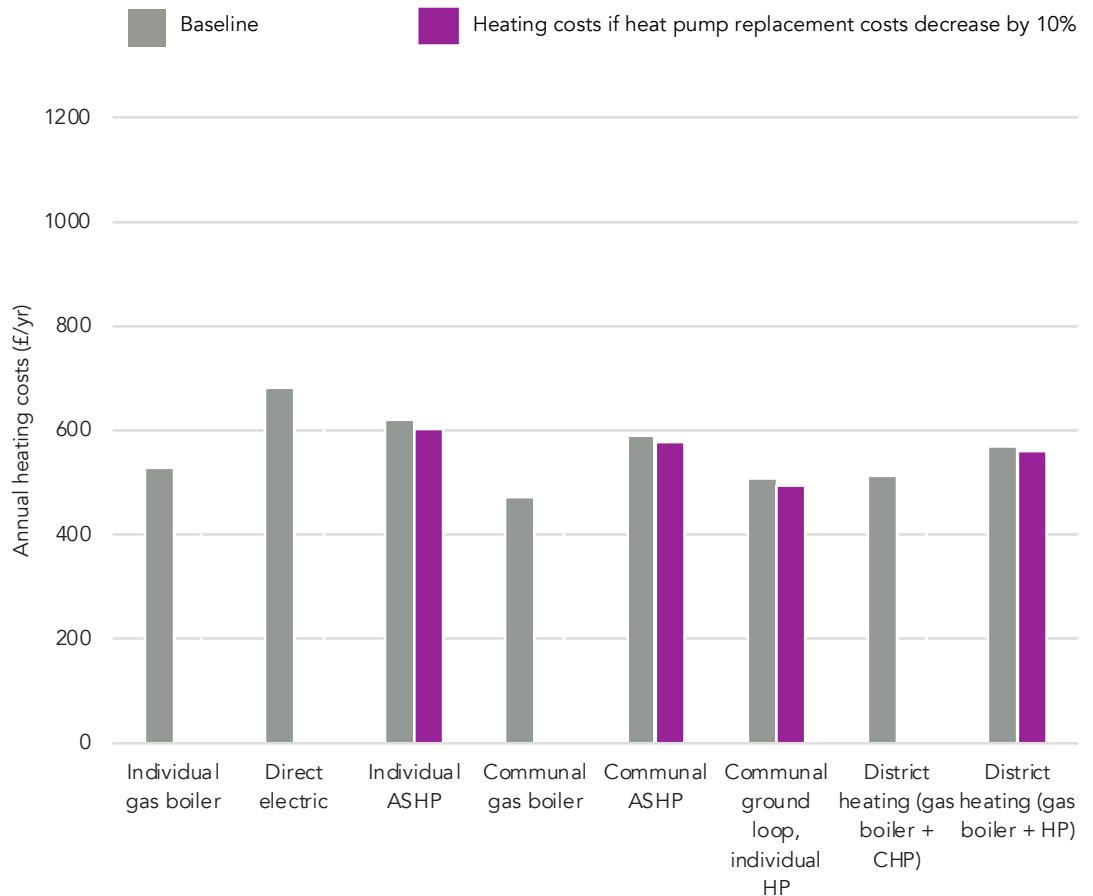
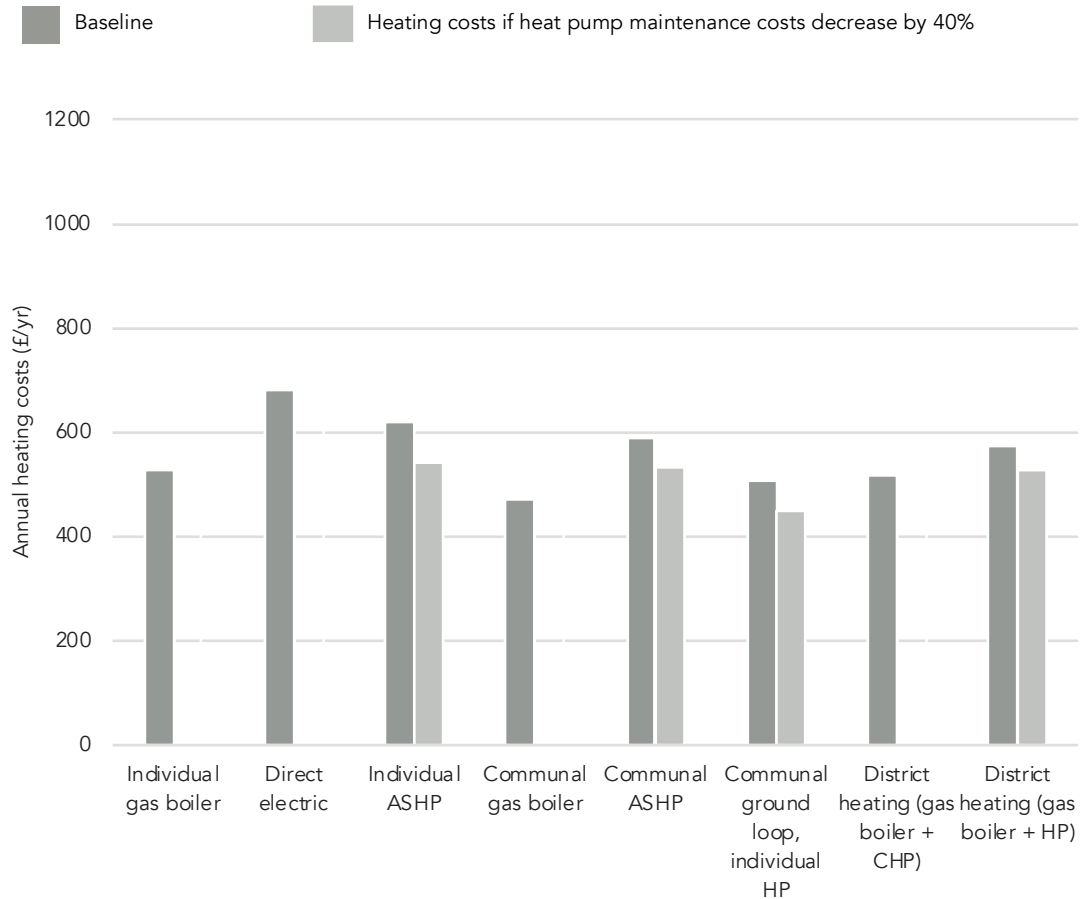

**Figure App K-13 - Impact of reduced heat pump efficiency on likely heating costs**

As can be expected, a modest reduction in replacement cost for heat pumps would have a slight positive effect on heating costs for heat pump solutions.

**What if the maintenance cost of heat pumps is 40% lower than assumed**

The figure below represents the impact of significant reduction in maintenance costs.



**Figure App K-14 - Impact of reduced heat pump efficiency on likely heating costs**

Maintenance costs of residential heat pumps are currently very high as the number of suppliers of maintenance services for this scale of systems is relatively small and much smaller than those able to maintain a gas boiler.

A significant reduction in maintenance cost can therefore reasonably be expected as the number of suppliers of heat pump maintenance services increases in the future. This would have a significant beneficial impact on heating costs for residents.

**Estimated impact of RHI**

The Renewable Heat Incentive (RHI) can have a significant impact on heating costs.

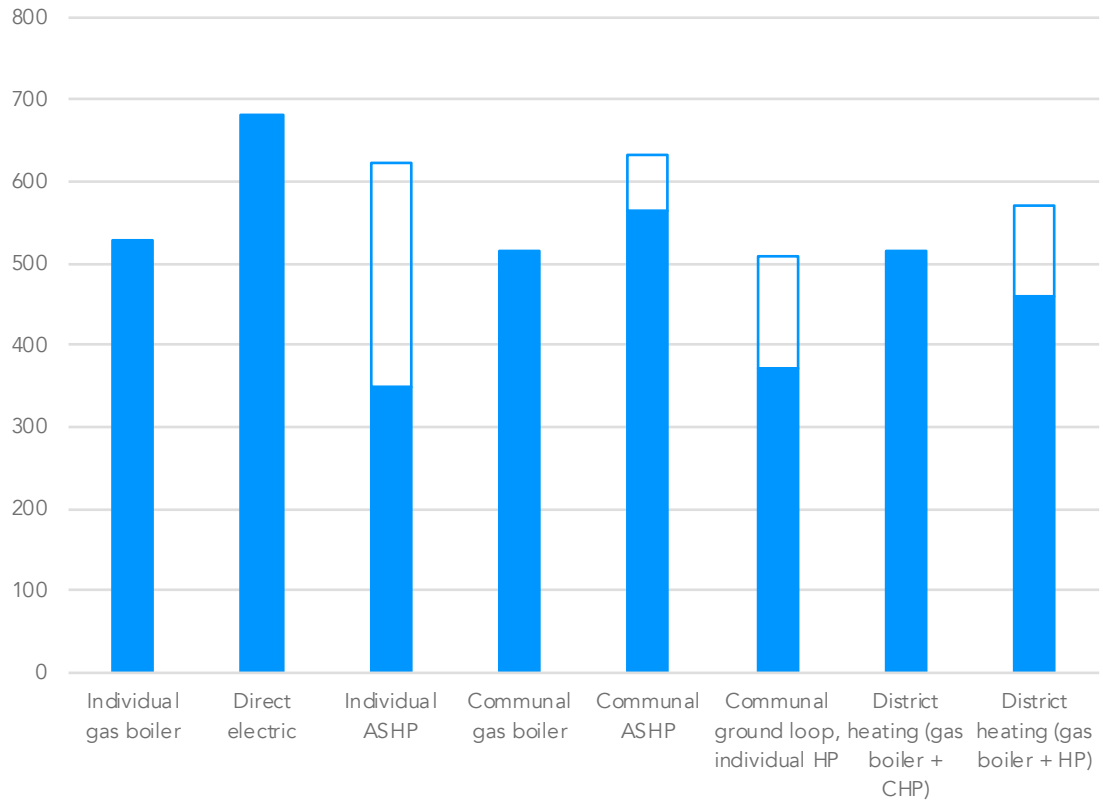

**Figure App K-15 - Impact of RHI on likely heating costs**

This analysis assumes that 100% of the Renewable Heat Incentive (RHI) savings are beneficial to the residents directly (e.g. individual air source heat pump) or passed on to residents in communal and district scale heat pump systems (for which commercial RHI tariff rates have been assumed).

The following RHI tariffs have been assumed:

- RHI air source heat pump tariffs: 10.49p/kWh (domestic) / 2.69p/kWh (commercial tier 1)
- RHI ground source heat pump tariffs: 20.46p/kWh (domestic) / 9.36p/kWh (commercial tier 1) / 2.79p/kWh (commercial tier 2)

As it can be seen, the RHI would have a positive to very positive impact on residents’ heating costs. With the RHI, individual air source heat pumps and the communal ground loop with individual heat pump systems would become the two most economic systems for the residents.

Passing on the RHI benefits to the residents is however not the norm for communal systems as it is generally used to help finance the capital costs of the system. If RHI benefits are not passed on the residents (which is a possible scenario) the RHI would not lead to a decrease in heating costs.